



# NAT SENSOR

**DUAL TECHNOLOGY SENSOR**  
(PIR + Microwave)

**Outdoor use**

*INSTALLATION MANUAL*

## 1. DESCRIPTION

- Dual Technology Sensor (PIR + Microwave).
- AND operation in the prevention of "false alarms".
- IP65 (indoor and outdoor).
- Mount directly to the wall or by "L" bracket.
- Sensibility adjustable PIR with angular aperture of about 6 °.
- Microwave K-band 24 GHz.
- IR range adjustable from 0 to 12m.
- MW range adjustable from 0 to 12m.
- Function and output ANTI-MASKING for infrared and microwave.
- High immunity to false alarms.
- RF immunity up to 2Ghz.
- Pet Immunity.
- Small size (135mm x 33mm x 40mm)
- Processing digital signals of PIR and MW.
- Security Function.
- Digital Filter 100Hz.
- Temperature Autocompensation.
- Environmental Autocompensation.
- Operativity Self scanning of PIR technology.
- Operativity Self scanning of MW technology.
- Tamper output combined anti-removal and anti-tear.
- Dip-Switch programming.

## NAT MOTHERBOARD

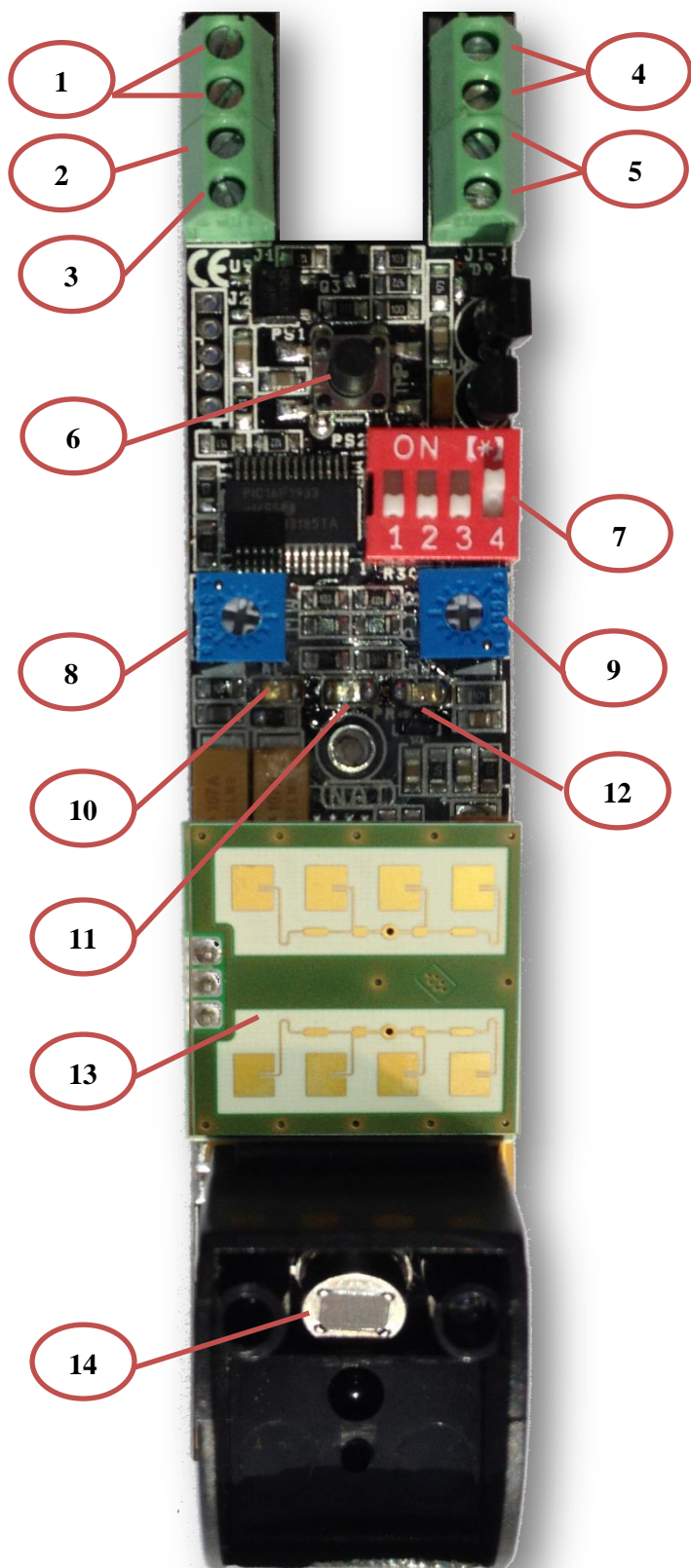

1	<b>POWER SUPPLY</b>	10-30 Vcc – GND Pay attention to the polarity.
2	<b>ANTI-MASK</b> (anti open collector negative)	Negative always opens in the event of masking.
3	<b>SBY</b> (positive input)	the system is inhibited if an + is connected
4	<b>TAMPER</b> (N.C. tamper output)	It opens in case of sensor tampering.
5	<b>ALARM</b> (N.C. alarm output)	It opens in case of detection MW+IR.
6	<b>TAMPER BUTTONS</b> (anti-removal and anti-tear)	If they get open give the opening of N.C.
7	<b>DIP SWITCHES</b>	System configuration. rotating in clockwise increases the range (sensibility) of MW.
8	<b>TRIMMER MW</b>	rotating in clockwise increases the range (sensibility) of IR.
9	<b>TRIMMER IR</b>	lit up when there is a general alarm, if enabled.
10	<b>RED LED</b> (ALARM)	lit up when there is a PIR alarm, if enabled.
11	<b>ORANGE LED</b> (PIR)	lit up when there is a Microwave alarm, if enabled.
12	<b>GREEN LED</b> (MW)	Detection sensor MW.
13	<b>MICROWAVE 24GHZ</b>	Detection sensor IR.
14	<b>PYROELECTRIC SENSOR</b>	

## 2. MOUNTING

The mounting of the NAT can occur in two modes or directly to the wall through the plate or "L" through the mounting bracket angular.

### WALL MOUNTING

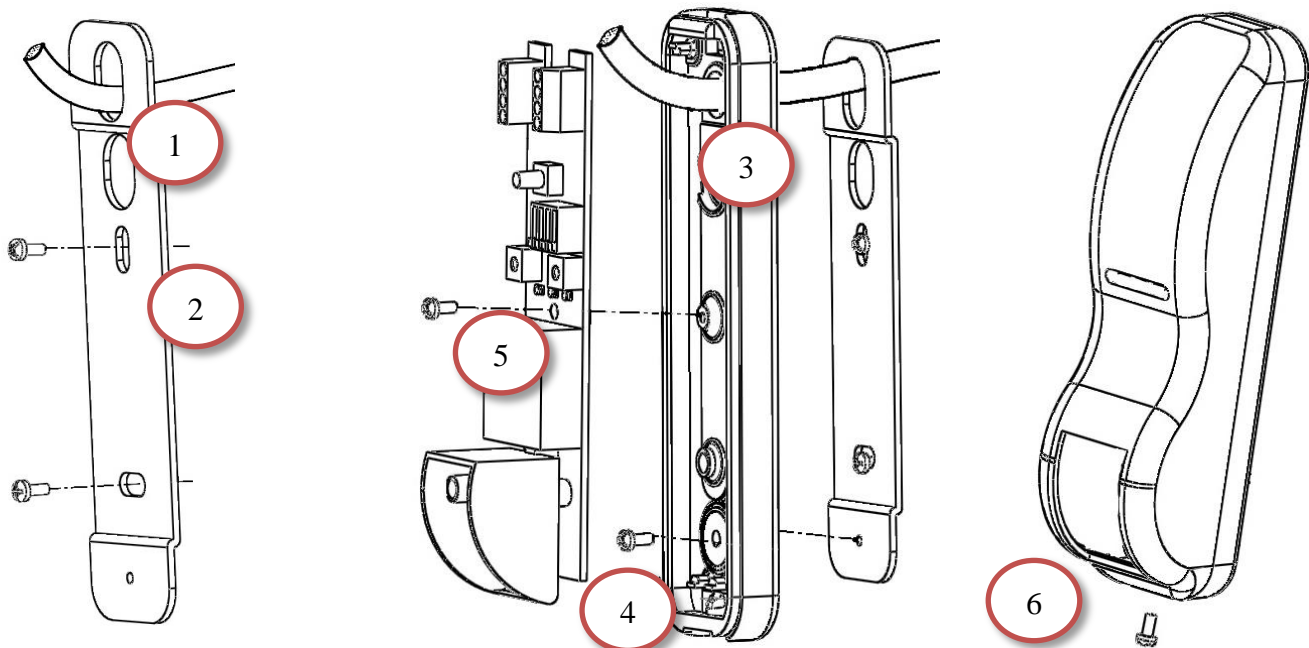

1. Insert the shielded cable alarm in the fixing plate;
2. Fix the plate at wall ;
3. Drill hole in the rubber nut and slide inside the cable;
4. Screw the base on the plate;
5. Fix the NAT motherboard on the support base and connect wires;
6. After the wiring and operation test close NAT sure that the seals and the O-rings are present and not damaged to ensure the integrity of the product.

## WALL MOUNT WITH “L” BRACKET

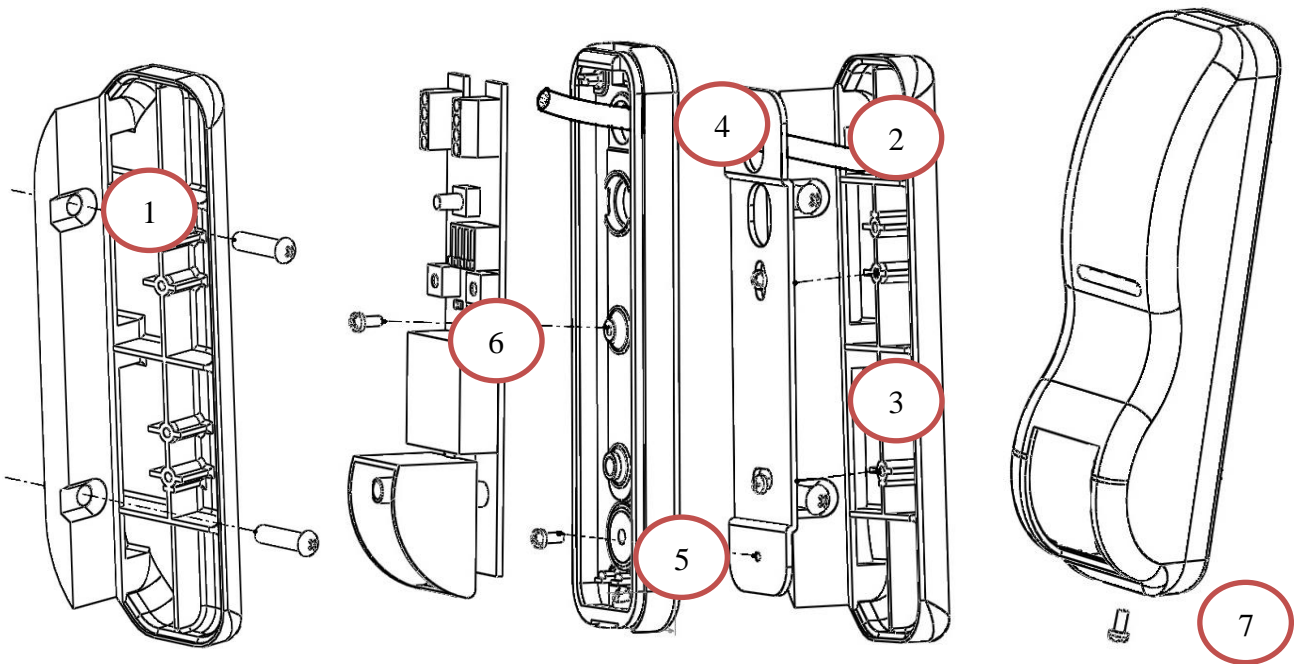

1. Insert the shielded alarm cable into the slots of the bracket angle and fasten it to the wall;
2. pass the cable through the mounting plate;
3. fix the plate to the fastening bracket angle;
4. Drill hole in the rubber nut and slide inside the cable;
5. Screw the base on the plate;
6. Fix the NAT motherboard on the support base and connect wires;
7. After the wiring and operation test close (7) NAT sure that the seals and the O-rings are present and not damaged to ensure the integrity of the product.

### 3. COVERAGE AREA

#### SIDE VIEW

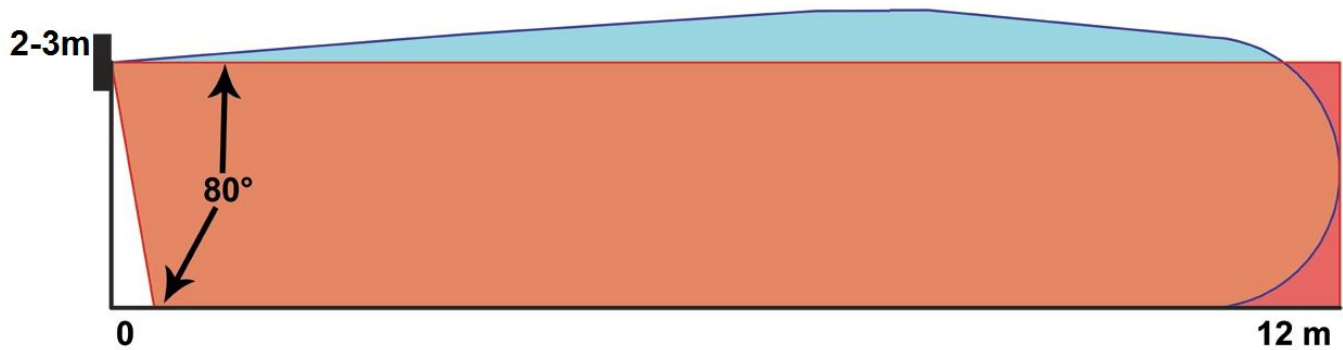

#### VIEW FROM ABOVE

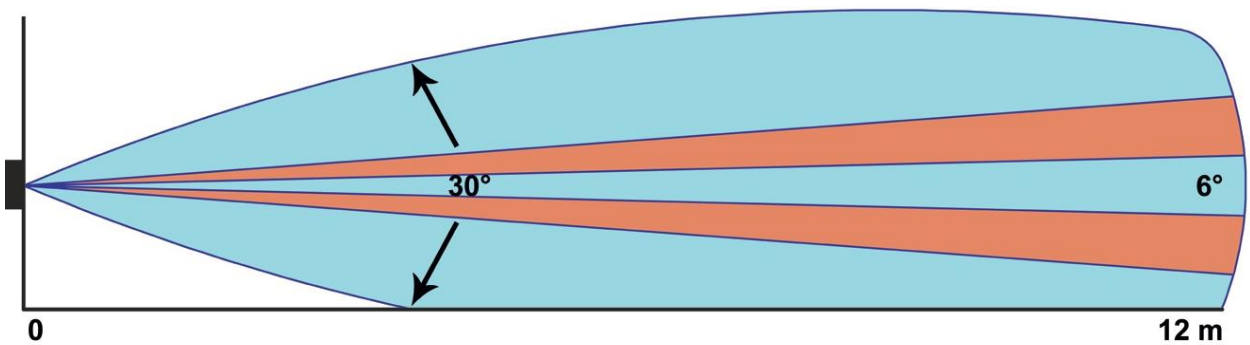

**NB:** The system can also detect the areas underlying the sensor Nat adjusting the range (sensitivity) of the two technologies (see below).



## 4. PROGRAMMIN AND OPERATION

Install the sensor Nat between 2 and 3 meters in height from the floor concerned following the instructions on page 4. Connect the power supply according to polarity (10-30V) and connect the outputs Alarm, Tamper and Anti-Mask in central according to their usage requirements.

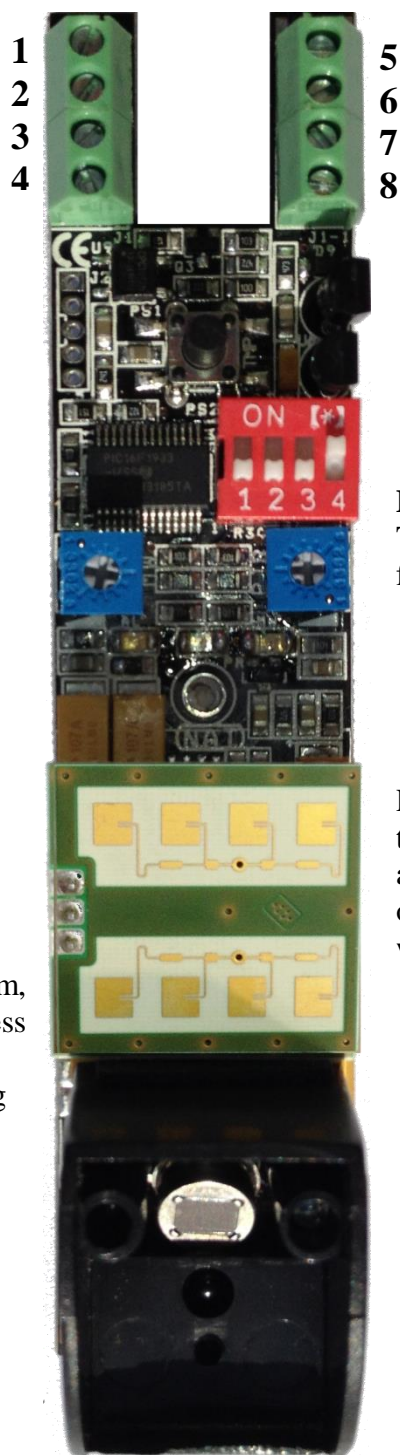

1	<b>+/GND</b>	Power supply of NAT 10/30Vdc.
2		
3	<b>ANTI-MASK</b>	Open collector negative. Opens in the event of masking.
4	<b>STAND-BY</b>	Positive input. the system is inhibited if an + is connected.
5	<b>TMP</b>	N.C. Tamper output. It opens in case of sensor tampering.
6		
7	<b>ALARM</b>	N.C. Alarm output. It opens in case of detection MW+IR.
8		



**MW RANGE (SENSITIVITY) 1-12m REGULATION TRIMMER:** Adjust the microwave range through the trimmer, implementing with crossing test. Submitting GREEN LED will help to verify the detection of the passage in different areas (exp. 0m, 4m, 7m, 12m). Test the goodness of the coverage of the affected areas, by adjusting the PIR.

### POWER LED ON FOR DETECTION TEST

Turn on the dipswitch number 4 for the functionality of the LEDs detection.

	1	2	3	4
ON				■

Power on for the duration of about 30 seconds if the DIP4 of the LEDs is activated you will see an alternate flashing of these, for the stabilization of the system. Term of flashes you can proceed with the following settings.



**PIR RANGE (SENSITIVITY) 1-12m REGULATION TRIMMER:** Adjust the PIR range through the trimmer, implementing with crossing test. Submitting ORANGE LED will help to verify the detection of the passage in different areas (exp. 0m, 4m, 7m, 12m). Test the goodness of the coverage of the affected areas, by adjusting the MW.

## 5. ADDITIONAL FEATURES

### FILTER DISTURBS

Turn the DIP switch number 1 to filter and reduce noise at 100Hz. caused by external agents such as NEON lights.

**N.B.:** Use this feature (reduced sensitivity) ONLY in the presence of such a source of disturbance in the extreme vicinity.

Carry out a repetition of the MW range adjustment and test the goodness of the coverage of the affected areas by adjusting the PIR.

	1	2	3	4
ON				

### ANTI-MASK

Turn the dipswitch number 2 for the functionality ANTI-MASK. Activating this function when an object is placed in front of the sensor to blind it and make it ineffective, an active infrared system checks for the presence of these in 3 seconds and gives an output signal through dedicated. The anti-mask microwave verification of the presence of an object check in 20 seconds the presence of an object and gives an output dedicated.

**N.B.:** If DIP 2 (anti-mask) and 4 (LED) are activated when it comes in a stealth mode, led blinking green-orange alert the opening of the contact ANTI-MASK.

**WARNING:** When activated the DIP 2 before leaving the installation spot, you MUST close the sensor NAT and you MUST power down and power up the entire system.

	1	2	3	4
ON				

### SECURITY FUNCTION

Turn the dipswitch number 3 functionality SECURITY. Activating this function if the MW sensor provides at least 7 distinct surveys in 30 seconds, the alarm signal from a system independently of the PIR sensor readings. Dually the IR sensor provides at least 4 separate surveys in 30 seconds, the system by an alarm signal regardless of the sensor readings MW.

	1	2	3	4
ON				

When the test and programming are ended turn off the LED settings provide to secure the cover.



## 6. DESCRIPTION OF NOT SETTABLE FUNCTION

### PET IMMUNITY SYSTEM

The system of pet immunity is able to discriminate the small animals up to a maximum of 10kg and not to give an alarm signal. In the case of animals such as dogs and cats perform function tests.

### SELF-DIAGNOSIS SYSTEM

The system will periodically check every 50sec about the functionality of the microwave and PIR system. In case of Malfunction of one of the two detection equipment, this is signaled by the flashing of the LED dedicated (GREEN and ORANGE for MW for IR), steadily. In this condition the system excludes the operation of the technology is not working and the detection will continue to be present in the OR mode.

### AUTO-THERMAL SYSTEM

The system detects the temperature of the surrounding environment through a dedicated sensor and modify the detection parameters of the IR sensor in order to adapt to extreme environmental conditions.

### AUTO-ENVIRONMENTAL SYSTEM

The system locates in the case of heavy rains and snowfall an environmental condition "different" after about 20 seconds and is able to adapt the system to the detection threshold by changing the parameters of both technologies for the duration of the event.

## 7. APPLICATION

Example 1: "wall covering"



The sensor can be commonly used for the protection of facades using the bracket to "L", and thanks to the new system of AUTO-ENVIRONMENTAL is able to reduce to zero the possibility of "false alarms". The installation MUST be carried out at height between 2 and 3m by adjusting the range and sensitivity of the two technologies (MW + IR).

Example 2: "Curtain for windows or doors"



## 8. TECHNICAL SPECIFICATION

	<b>Description</b>	<b>Value</b>
<b>Max range detection IR</b>	Adjustable	1-12m
<b>Max range detection MW</b>	Adjustable	1-12m
<b>MW Frequency</b>	/	24.125Ghz
<b>Angle IR coverage</b>	/	80° vertical – 6° horizontal
<b>Angle MW coverage</b>	/	80° vertical – 30° horizontal
<b>Power supply</b>	/	10 – 30 Vdc
<b>Absorption on alarm</b>	/	42mA
<b>Absorption standby</b>	/	40mA
<b>Alarm Output</b>	N.C.	/
<b>Tamper Output</b>	N.C.	/
<b>Max range detection IR</b>	Open collector -	/
<b>Stand-by input</b>	INPUT +	/
<b>Operating Temperature</b>		-20°+65° C
<b>Dimensions</b>		135mm X 33mm X 40mm
<b>Weight</b>		150gr
<b>Mounting brackets</b>		

**TOTAL WARRANTY 2 YEARS**



**POLITEC s.r.l.**

Via Adda, 66/68 - 20882 Bellusco (MB) - Italy  
tel. +39 039 6883019 r.a. - fax +39 039 6200471  
[www.politecsrl.it](http://www.politecsrl.it)