



# MANA MW 25

Microwave barrier for perimeter protection at long range.  
Installation manual .

# Index

---

<b>Principal Component</b>	<b>Page 3</b>
<b>Pit Assembly</b>	<b>Page 4</b>
<b>Pit Placement</b>	<b>Page 5</b>
<b>Installation problems</b>	<b>Page 7</b>
<b>Possible correction of incorrect positioning</b>	<b>Page 8</b>
<b>Connections TX</b>	<b>Page 9</b>
<b>Connections RX</b>	<b>Page 11</b>
<b>Connections power supplier</b>	<b>Page 14</b>
<b>Connections and descriptions cavity Tx and Rx</b>	<b>Page 16</b>
<b>Connections notes</b>	<b>Page 17</b>
<b>Sensitive area</b>	<b>Page 19</b>
<b>Deadzone</b>	<b>Page 20</b>
<b>Operation mode</b>	<b>Page 21</b>
<b>Specifications</b>	<b>Page 24</b>

# Principal Component

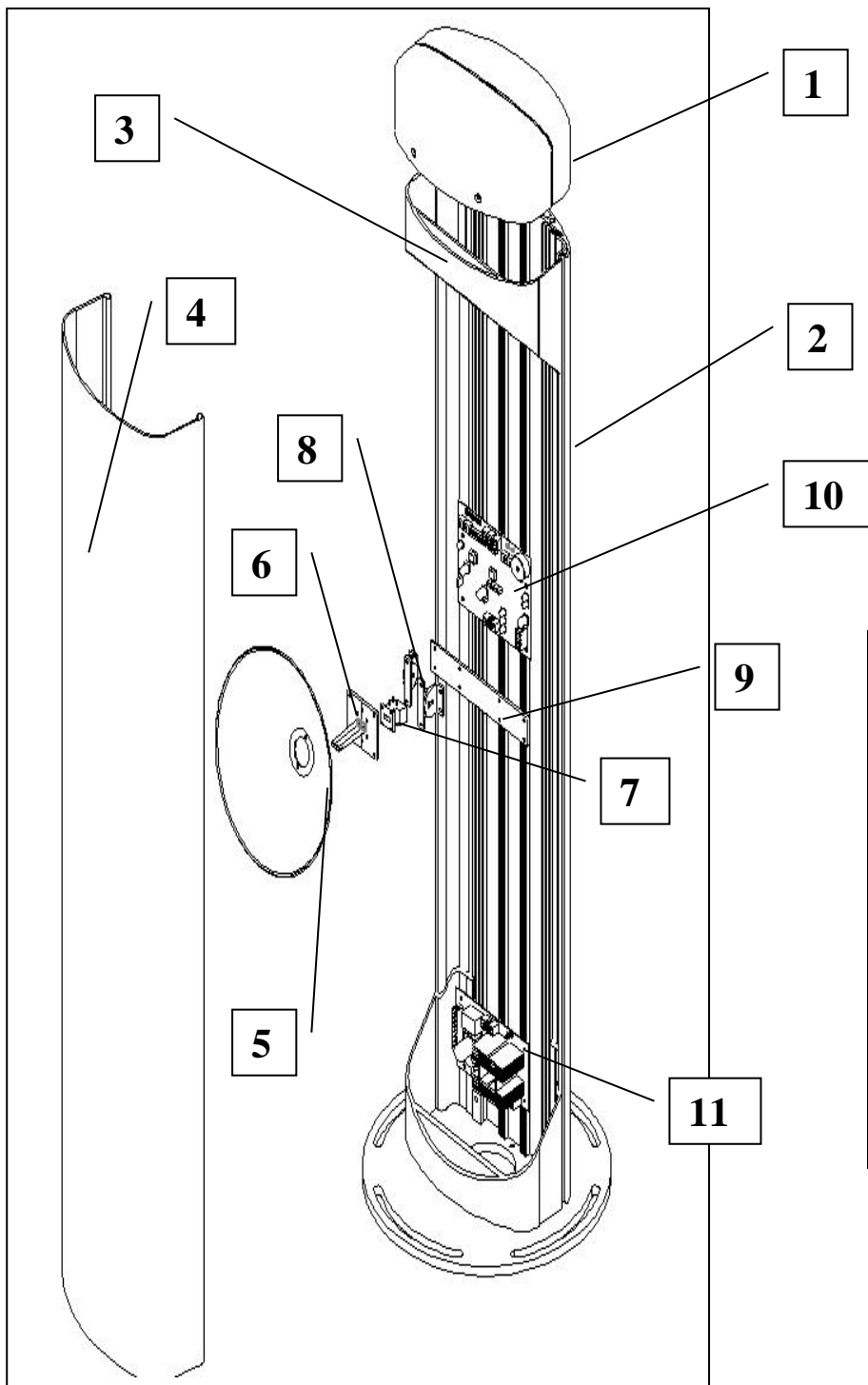

N. Parts	Quantity	Description
1	1	Top Cap
2	1	Aluminium Profile
3	2	Aluminium inserts
4	1	IR cover
5	1	Parable Mana
6	1	Illuminator Mana
7	1	Cavity Tx or Rx
8	2	Handling system
9	1	Plate
10	1	Tx or Rx board
11	1	Power board

# Assembling the cable pit

---

The cable pit has two functions; the first is to permit easy connection of all the cable ducting and conduit and secondly as a hold solid base to mount the beam tower.

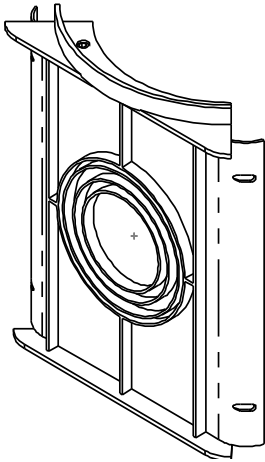

**Single cable pit side panel**

---

**Use the supplied nuts and bolts to assemble the cable pit. Overlap the right-hand edge of one side pan to the left-hand edge of the next.**

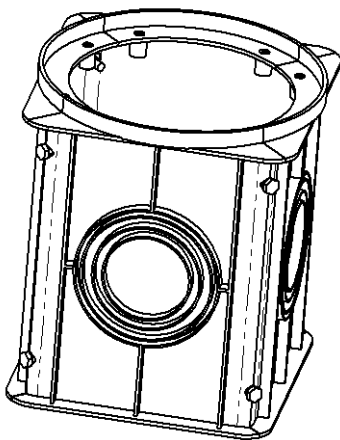
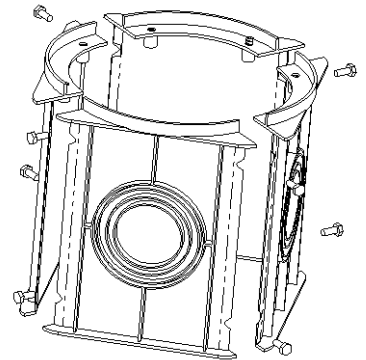

**Assembled cable pit, ensure that the mounting flange is uppermost.**

## Positioning the cable pit

---

Once fully assembled the cable pit is installed ten centimeters below ground level and is embedded in concrete; once correctly installed it can be covered (with turf or suitable decking) so that only the IR beam tower is visible .

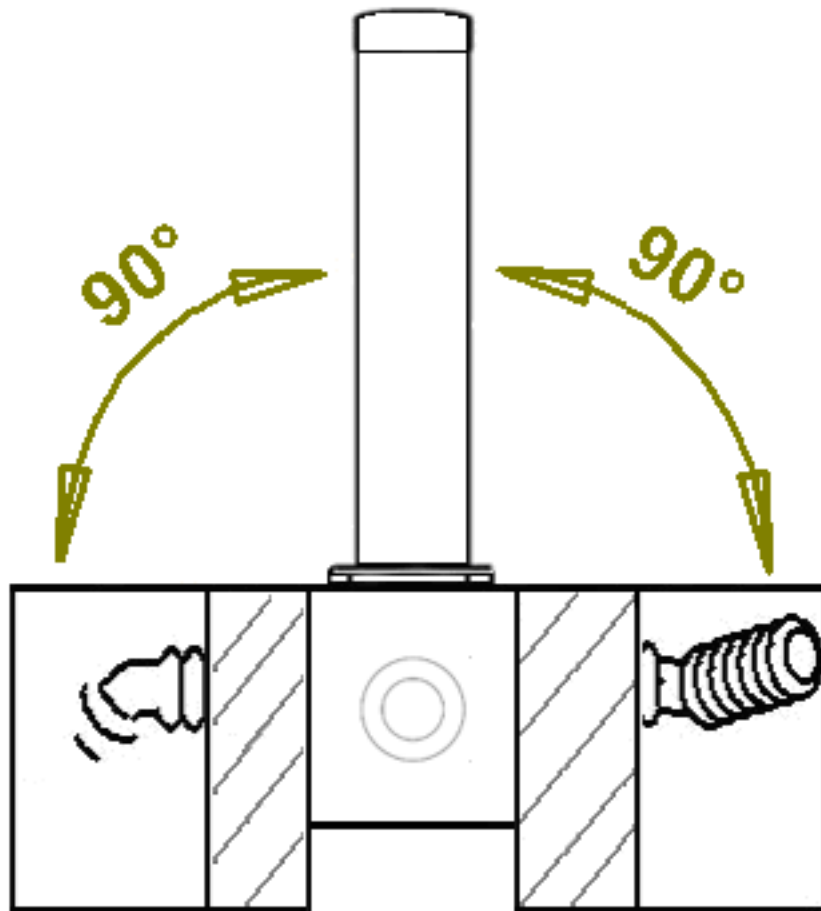

# Correcting a incorrectly installed cable pit

The mounting flange has to be level so that the Parvis beam can be installed correctly.

Small adjustments, to make the beam sit perfectly vertically, can be made via inserts in the top face of the cable pit flange. Underscrewing the insert raises it thus raising the base of the tower on that side, adjusting the correct inserts will bring the beam back to the vertical.

Incorrect installation.

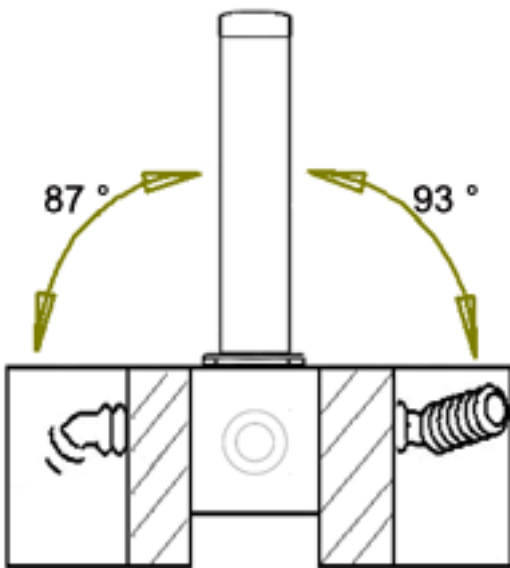

Correct installation

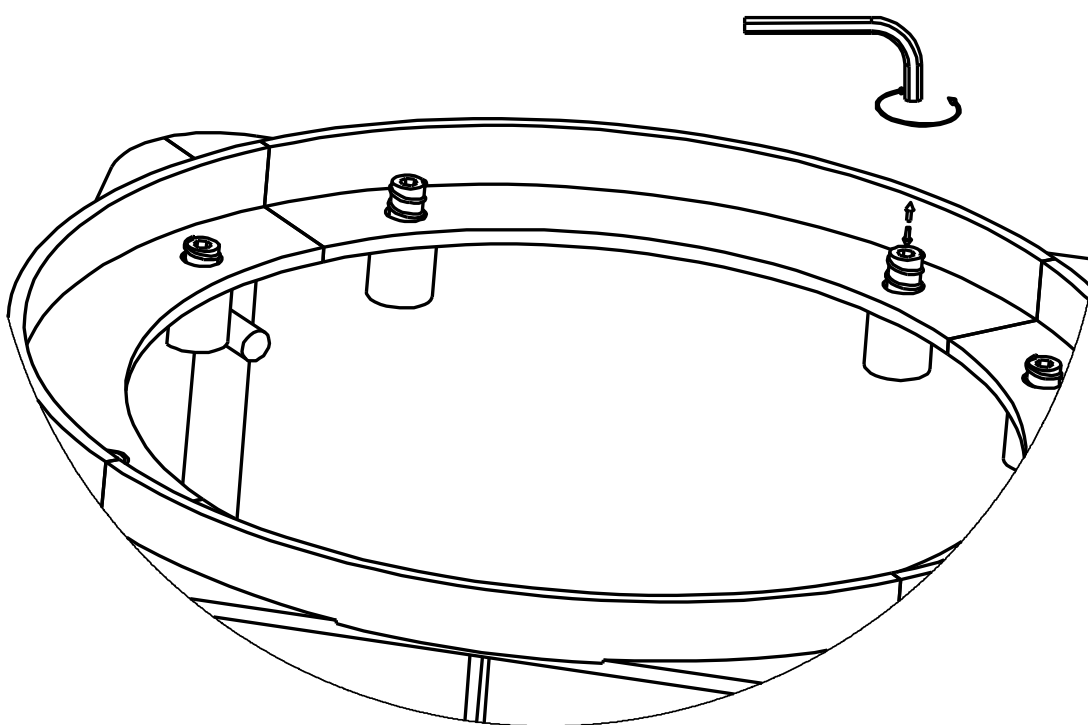
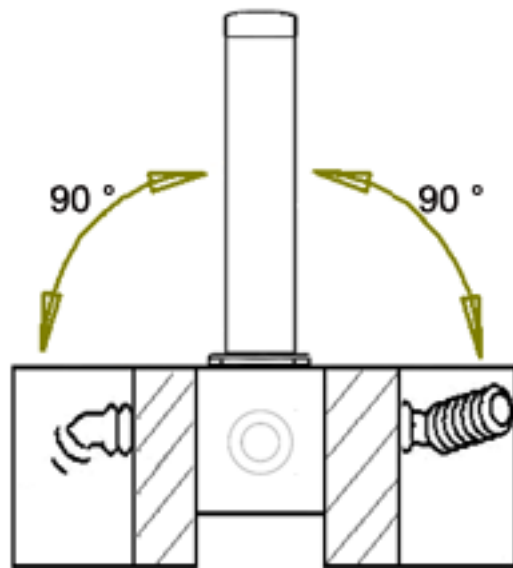

How to make small adjustments

# Installations Problems:

- **Number of sections**

Having to design protection with volumetric barriers of a closed perimeter within a certain number of sections that take into account the management need of the entire plant, it must be remembered that it is always preferable to install an even number of sections. This consideration is bound to the fact that the likely reciprocal interferences between adjacent sections are annulled should at the vertices of the polygon (cross), resulting from the installation of the various sections, be installed two equipment with the same name, two transmitters or two receivers. It is evident that this might occur only if the number of sections is even. Should it not be possible to have an even number of sections then some careful considerations must be made on interferences that might likely occur in order to find the vertex point where retained best to place the transmitter near the receiver. The following pictures show some typical cases for which the most correct solution is given.

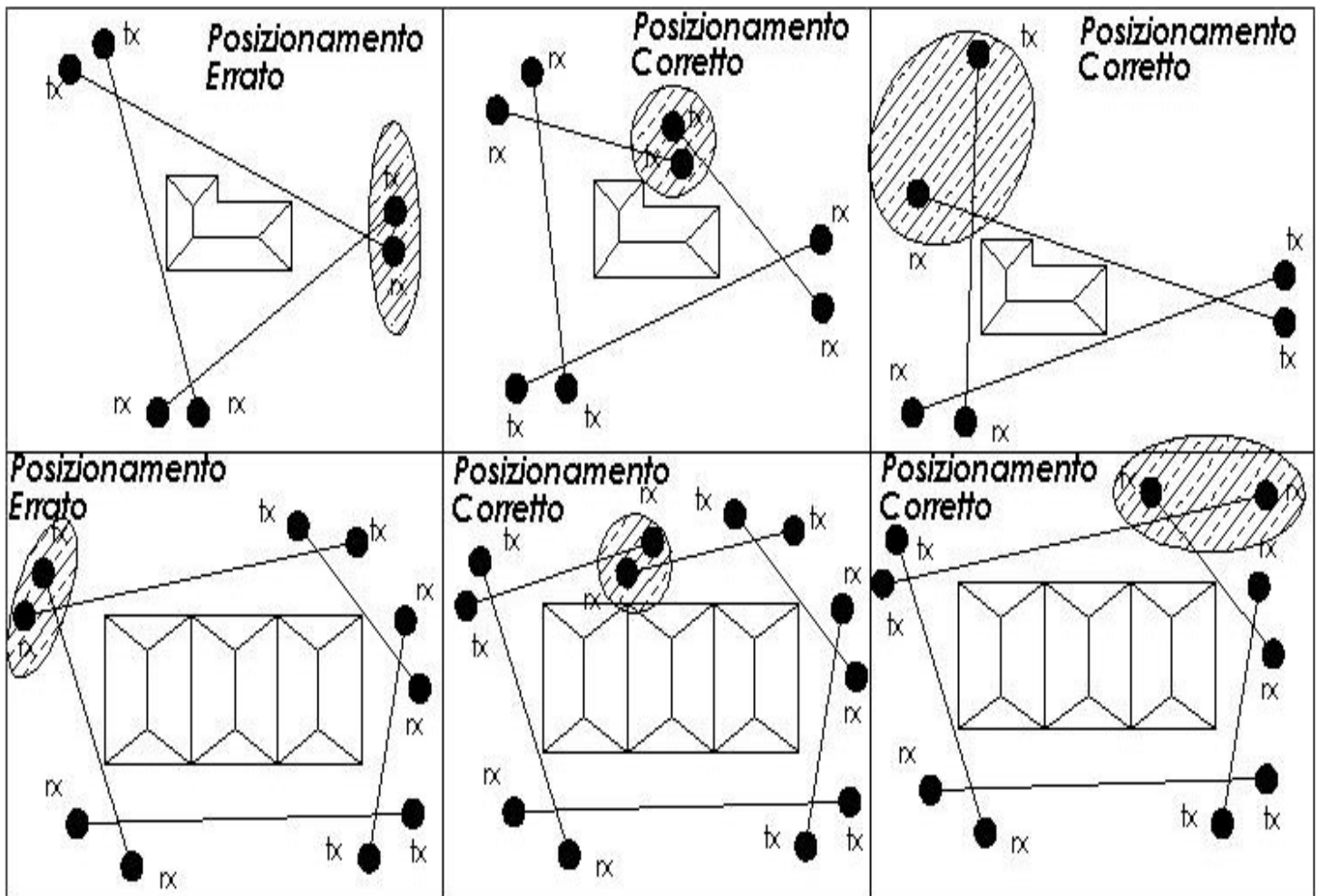

## • Particular conditions

1. **Ground conditions:** It is inadvisable to install the equipment along sections with tall grass (more than 10cm), ponds, longitudinal waterways, and all those types of grounds whose structure is rapidly mutable.

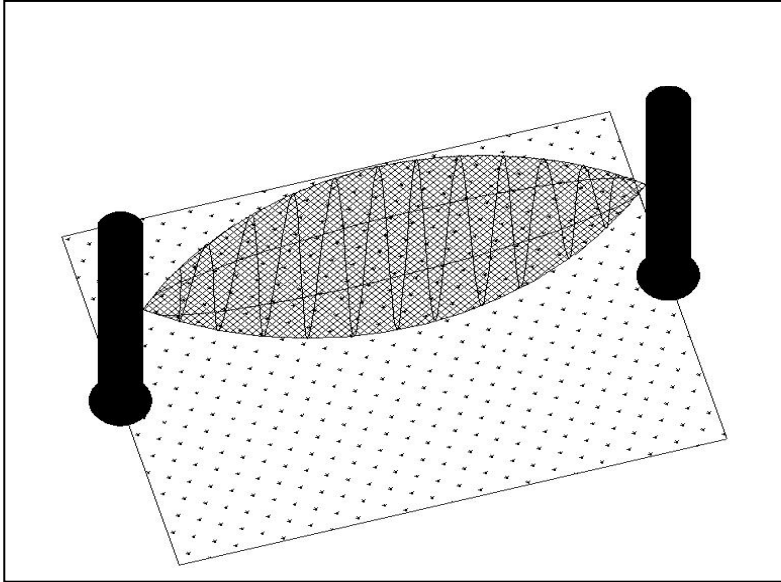

2. **Obstacles:** the fences, are generally metallic therefore highly reflecting hence causing various problems, for this reasons some precautions are suggested:

- First of all, make sure that fence has been properly fixed in order that the wind does not move.
- If it is possible the microwave beam shouldn't be placed in parallel to a metallic fence, is necessary to create a corner with it
- Metal fences placed behind the equipment might cause distortions to the sensitive beam especially, and might cause movement detection in unexpected spots, with subsequent likely generation of false alarms.
- In case of Mw barrier should be installed in a corridor between two metallic fences, the width of the corridor should be necessary not less to 5m.

Along the section, within the area of the protection field, are allowed pipes, poles or similar as long as their dimensions, with respect to the protection beam, are not too excessive. The trees, hedges, bushes in general, need very great attention if near or within the protection sections.



# Connections and circuit descriptions TX

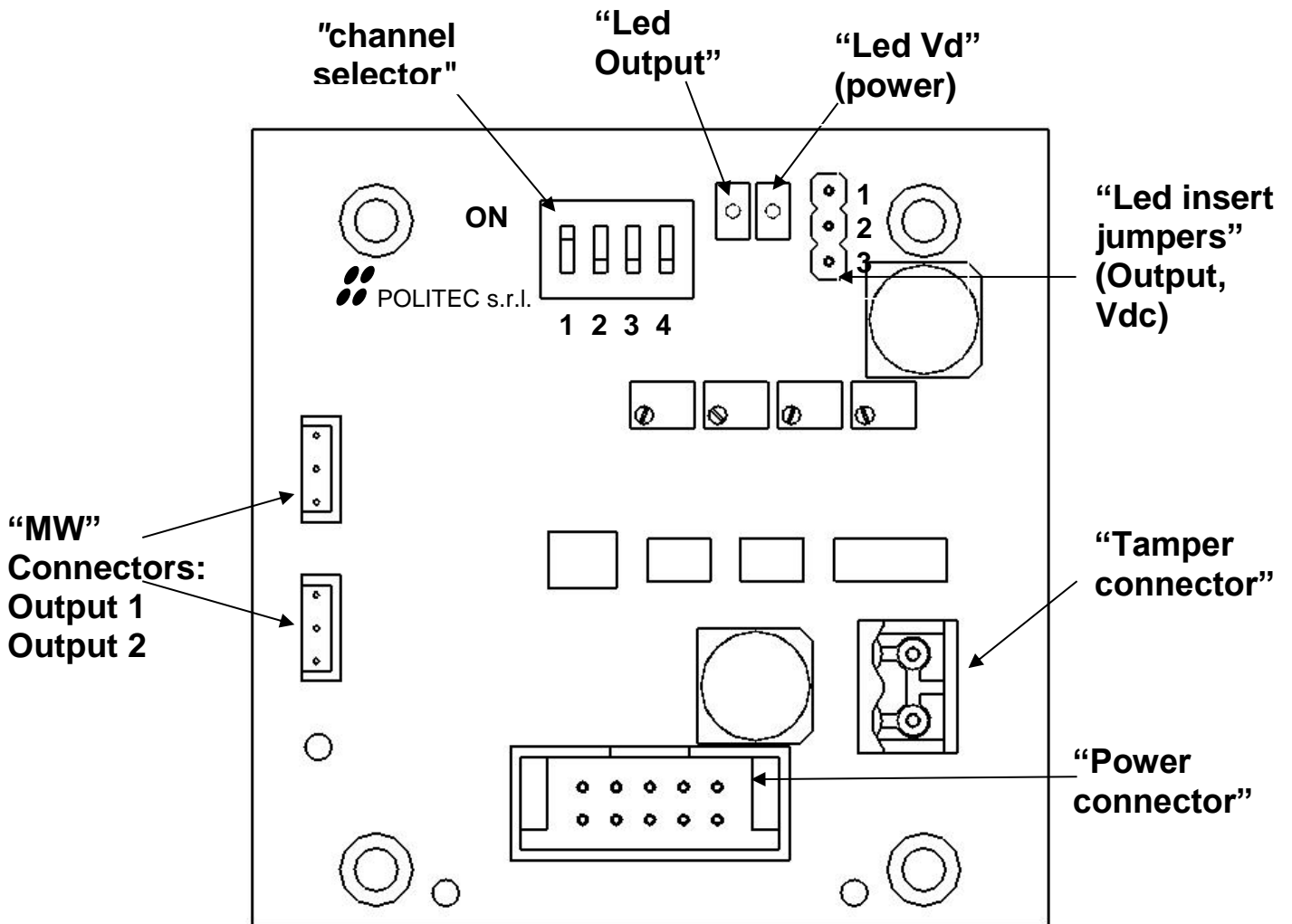

- The power connector is linked to power supplier via a flat cable.
- The connectors "MW" or Output 1 / 2 are used to connect the cavity transmission. Normally uses the output "Output 1", and only in case of double barrier microwave using the synchronized output "Output 2".
- The "Led insert jumpers", inserted in position 2-3, enables the power of Led Output "and" Led VDC ", indicating the presence of their tensions. Return after the test at rest 1-2. NB The "Output LED" has a lower light intensity of Led VDC, when the cavity "TX" is inserted.
- The "channel selector" allows you to select the desired channel by switching to "ON".  
NB The selected channel must be the same as that of the Circuit "Rx".

# Connections TX

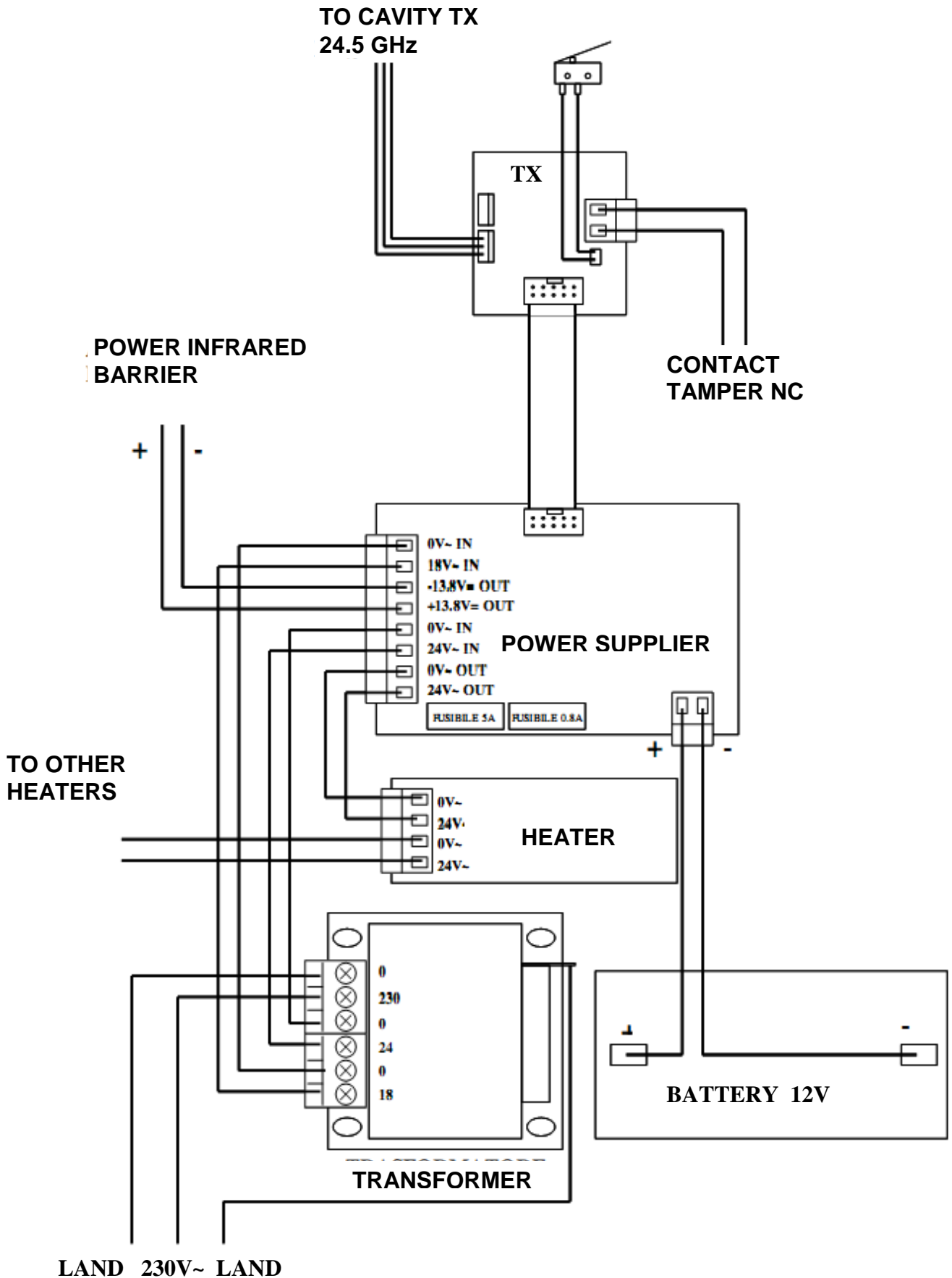

# Connections and circuit descriptions RX

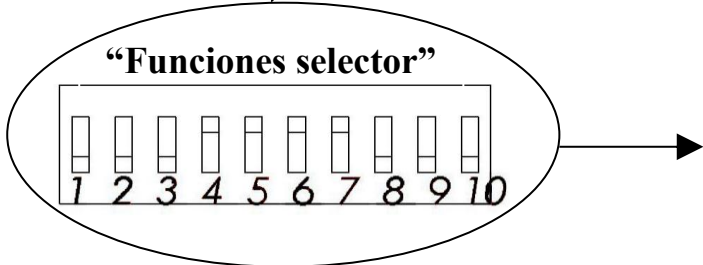
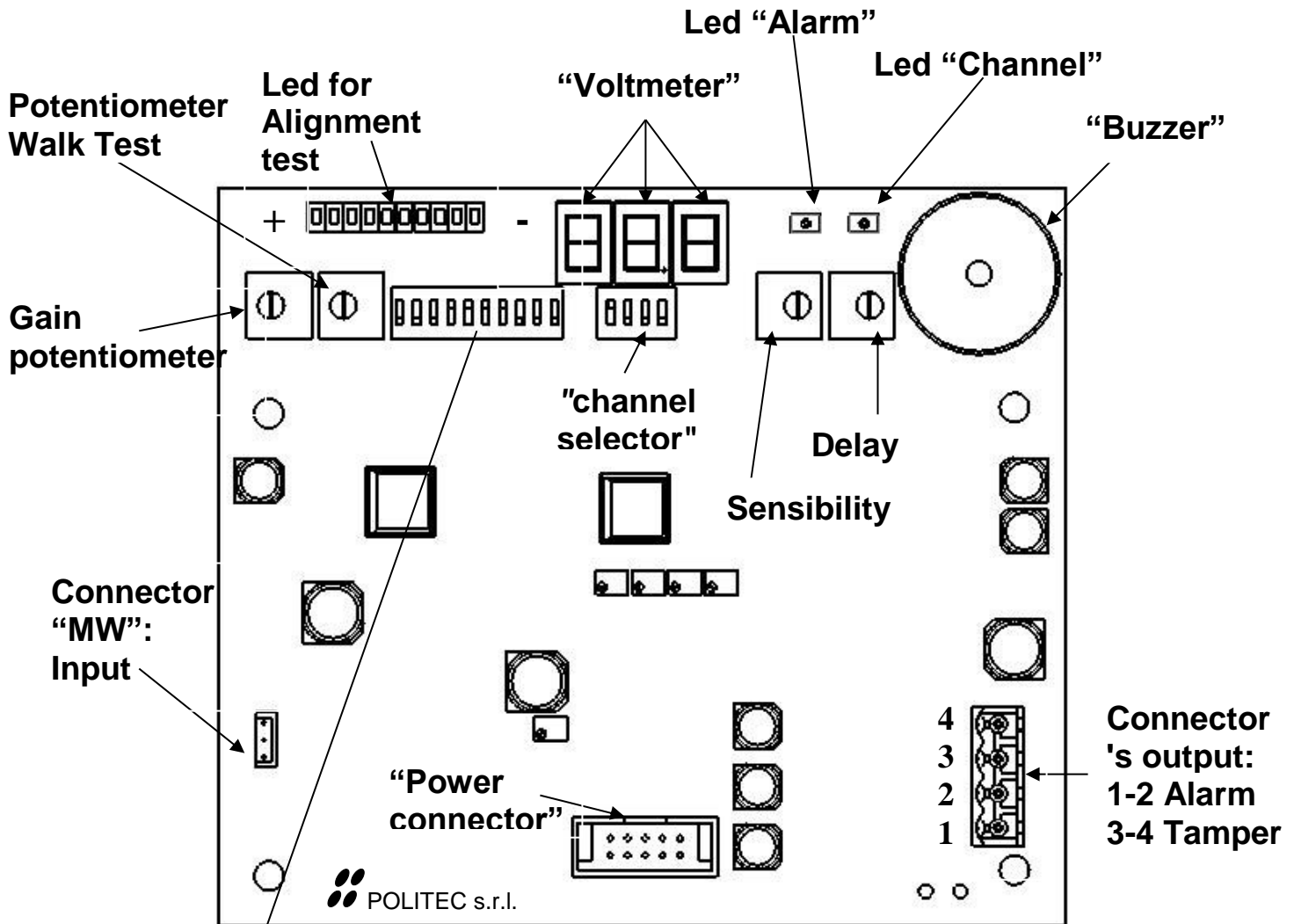

1: Insert LED bar for Test Alignment
2: Display on LED bar signal Rx strength
3: Disconnect CAG (automatic gain control)
4: Walk Test (skill the "Buzzer")
5: View the gain value (optimum 4.5-6.5)
6: Display Value Sensitivity (0 to 9)
7: Display $0.2 \pm 5V$ supply
8: Display $0.2 \pm 9V$ supply
9: Display $13.8 \pm 0.3$ supply
10: Input Voltmeter (to display items $5 \div 9$ )

- The "Input Connector Mw" is used to connect the receiver cavity.
- "Output Connector":  
1-2, NC alarm contact  
3-4, tamper contacts.
- The power connector is connected to power via a flat cable.
- The "Functiones selector" allows you to check the voltage supply, the value of sensitivity, goodness of the signal, the walk test and the test alignment (see table previous page).
- The "Channel selector" allows you to choose the desired channel by switching to "ON". NB The selected channel must be the same as that of the Circuit "Tx".
- The "Channel LED" indicates that the channel is tuned with the transmitter.
- The "LED Alarm" indicates that the system is not in alarm (when there is the alarm LED goes off).
- The "Voltmeter" indicates the voltage in volts of the selected function (see table previous page).
- The "Led Alignment" indicates the signal strength received:  
Red = weak signal;  
Yellow = signal Fair;  
Green = Strong Signal.
- Potentiometers (Gain, Walk Test, sensitivity, delay), adjustments to be made during installation
- The "Buzzer" (or buzzer) is activated with the "Walk Test" (selector functions):  
Continuous beep = Alarm  
Sound intermittently variable = Tell sensitive area.

# Cablaggi Barriera RX

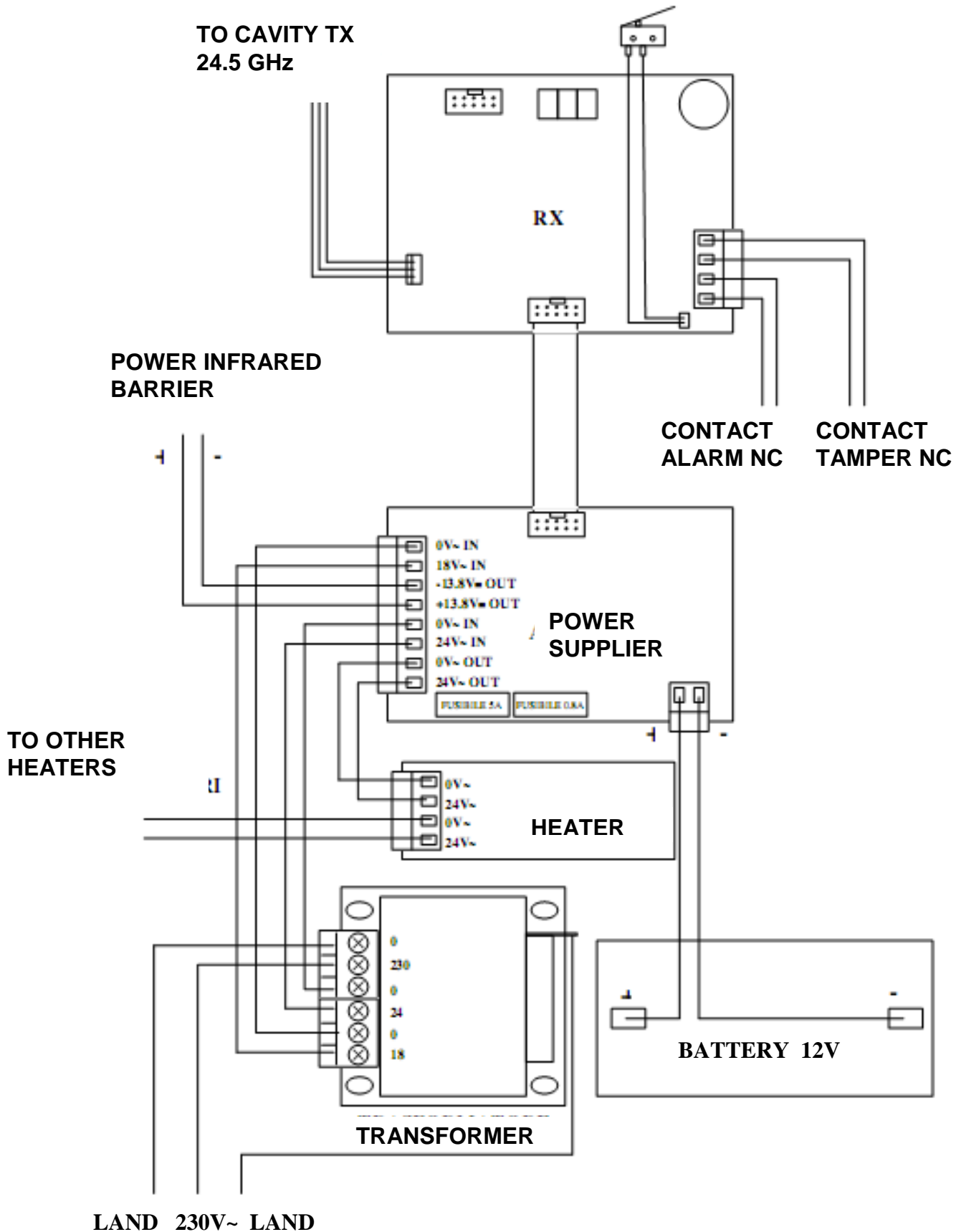

# Connections and descriptions ballast

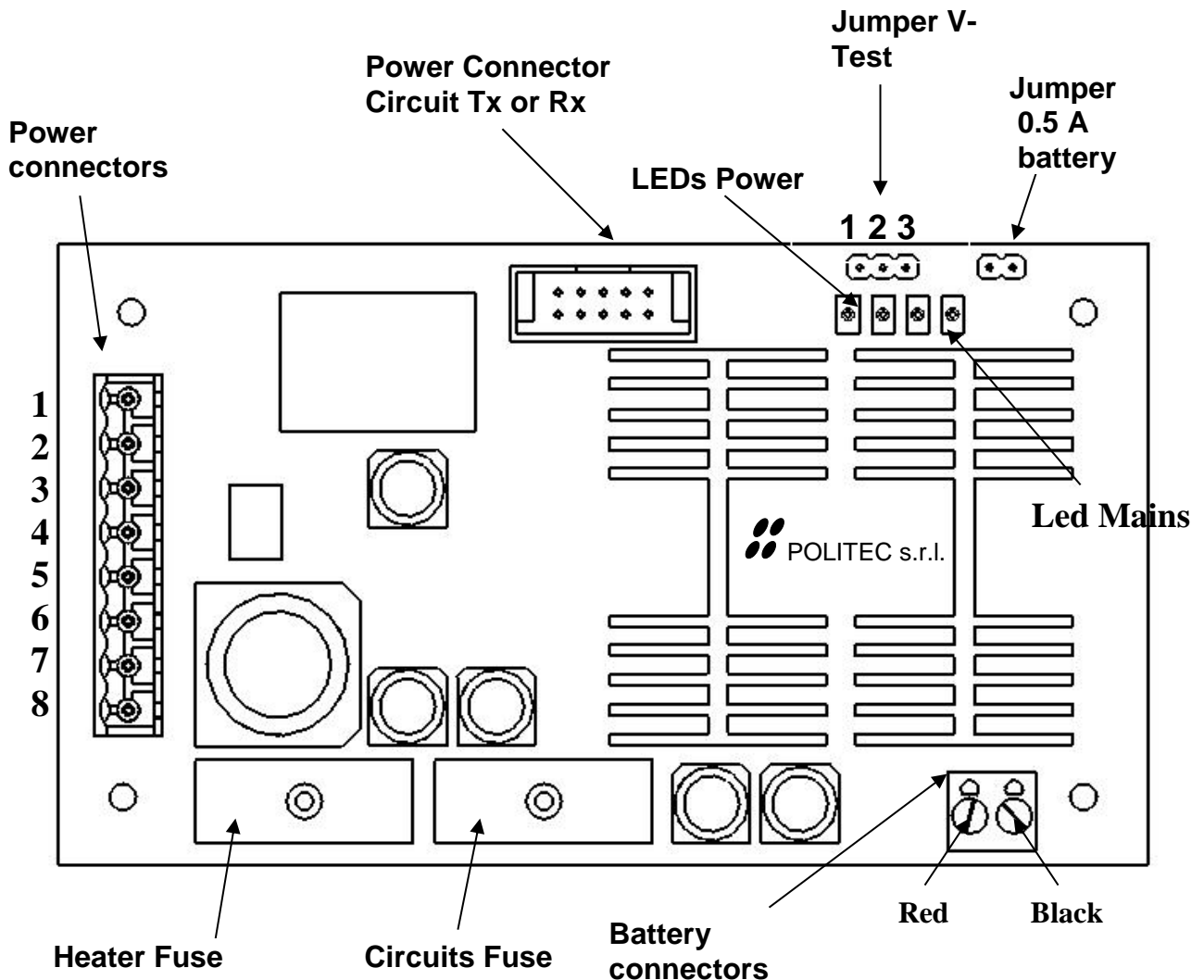

- "Power Connectors":**  
 1-2 = 19 VAC input to connect to the transformer  
 3-4 = 13.8 V output power for infrared  
 6.5 = 24 VAC input to be connected to the transformer  
 7.8 = 24 VAC output to connect the heaters.
- "Power Connector Circuit Tx or Rx"** is to be connected with flat cable to the power connector board Tx or Rx.

- **"Jumper V-Test" inserted in position 1-2 enables the lighting of LED power supply, 5V 9V 13.8V. Return after the test at rest position 2-3. The 4<sup>th</sup> Led called "Mains" is always seen when the board is powered by the transformer while it is off if the battery involved.**
- **"Jumper 0.5 A battery". Insert jumper when using more than 5 Ah batteries. NB Current limit for battery charging 0.5 A. Without the current bridge load limit is 0.25 A.**
- **" Heater Fuse " normally installed 5 A delayed protecting heaters circuits.**
- **" Circuits Fuse " normally installed by 0.8 A slow, protecting Tx or Rx and infrared circuits.**

## Connections and descriptions cavity Tx and Rx

---

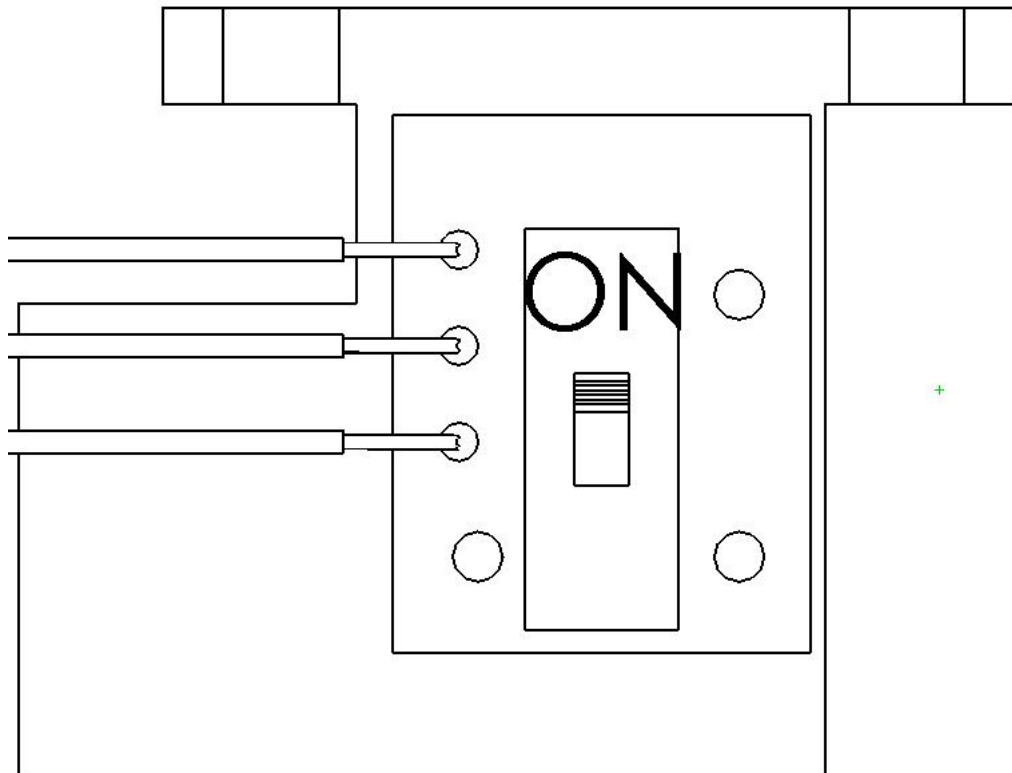

- The switch located on the cavity Tx and Rx is positioned to OFF only after installation and after giving voltage to the columns. The ON position, the active protection of the "receiver" cavity by electrostatic discharge and damage resulting from installation.



## Connections notes

---

- **Connection to the mains:**  
Columns can be powered by 19V AC to 13.8V DC, but is preferable by the last.
- **Connection:**  
The connection between the transformer and the 230 V ~ must be made with cables whose section is approximately 1.5 mm<sup>2</sup>. It is strongly recommended to use an upstream fuse 1 A delayed. The cable that carries power from the transformer to MANA will be as short as possible, should come with shield grounded. The two wires must be connected to terminals 1-2 of the "power connector". The transformer used must have the following characteristics:

Primary voltage	=	230 V~
Secondary voltage	=	18 o 19 V~ 1 A
Secondary voltage	=	24 V~ 6 A
Minimum power	=	160 VA

**NB:** Use only safety transformers with a certificate, such as 60950. Must be given good grounding of the housing processor. Connecting the transformer to 230 V ~ must be made through a device that has the following characteristics:

1. Bipolar with minimum distance between the contacts of 3mm
2. Provided in the fixed installation
3. Easily accessible

***In any case, you should carefully follow the requirements contained in the related law of fixed devices permanently connected to the mains as the Law 46/90 and CEI 64-8.***

In the case of mains very disturbed to add an effective filter 230V 1 A

- **Connection to the Emergency supplier:**

Within each column is provided space to house a rechargeable Lead 12 V - 1.9 Ah. The internal battery is normally recharged from food through a current limiter.

**NB:** The casings of the battery used, shall have a flammability class HB or better (UL 94)

- **Connection to the central**

Connections to the central processing must be made through shielded cables.

- **C / o contact Alarm:**

The outputs of the devices consist of relay contacts normally closed for reporting states and tampering alarm.

The contact output to alarm consists of a static relay with a range from 12V 1A.

Tamper output contact is given by the microswitch, with scope 100mA max.

The outputs are enabled for the following reasons:

**Alarm Output**

1. Intruder alarm on Rx
2. Alarm Channel on Rx

**Tamper Output**

1. Opening the cap of barriers

**NB** The High Risk Protection is essential that the detectors are tested with adequate intervals to Test Operational. In this way the control unit will be able to detect attempts to circumvent.

# Sensitive Zone

The sensitive area depends on the distance Tx Rx, the sensitivity and the type of antenna. The diagram below illustrates the sensitive area of diameter at half length as a function of total distance and sensitivity.

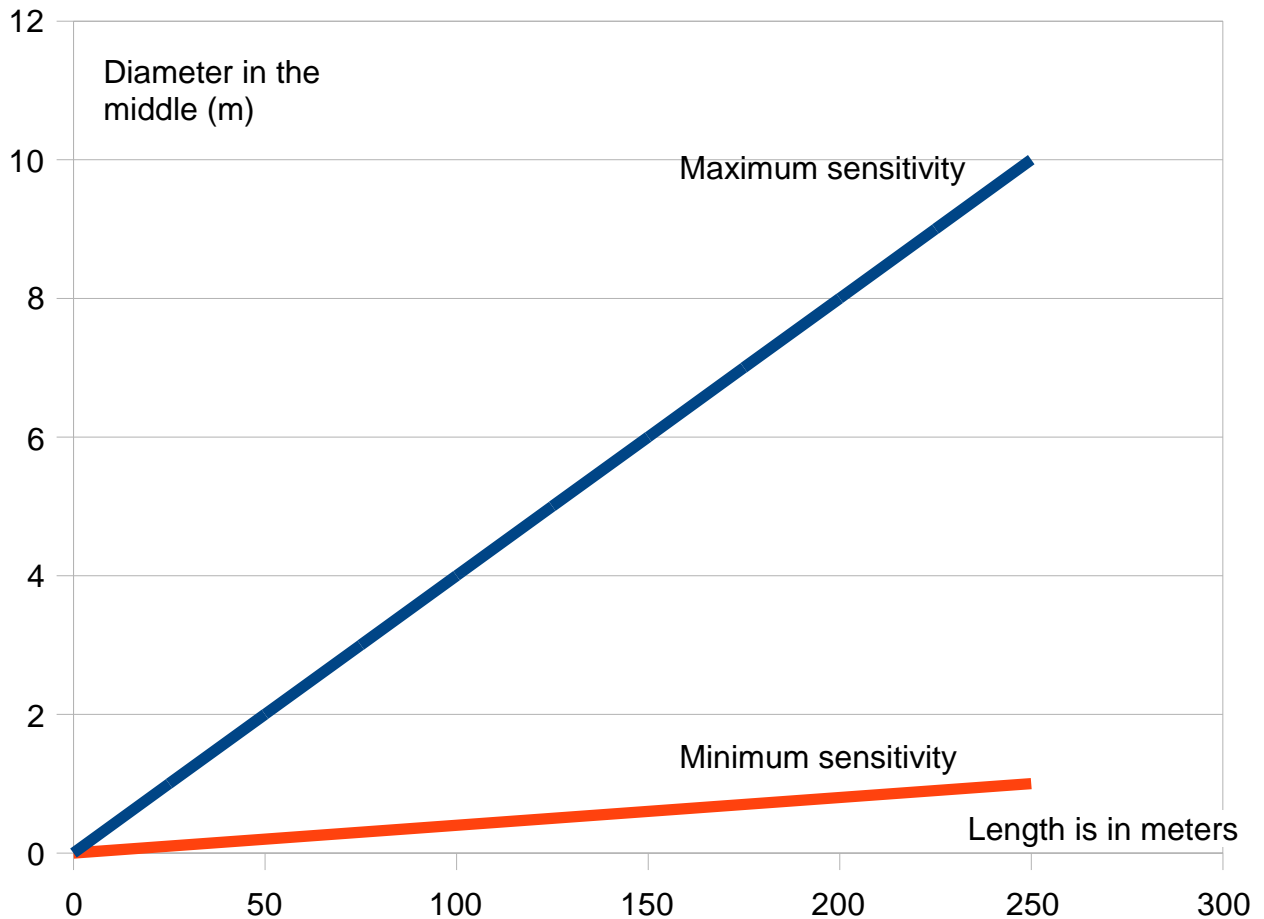

**NB:** remember to adjust the sensitivity of "MANA" according to half width of the beams is desired. As the threshold is higher, the lower the sensitivity and vice versa.

# Dead Zones

The length of dead zones in the vicinity of the columns is on the same apparatus is the distance from the ground, the sensitivity is set to the Rx circuit. *The recommended height for installation of a conventional type is approximately 70 cm from the center of the antenna to the ground, with the sensitivity set to medium.*

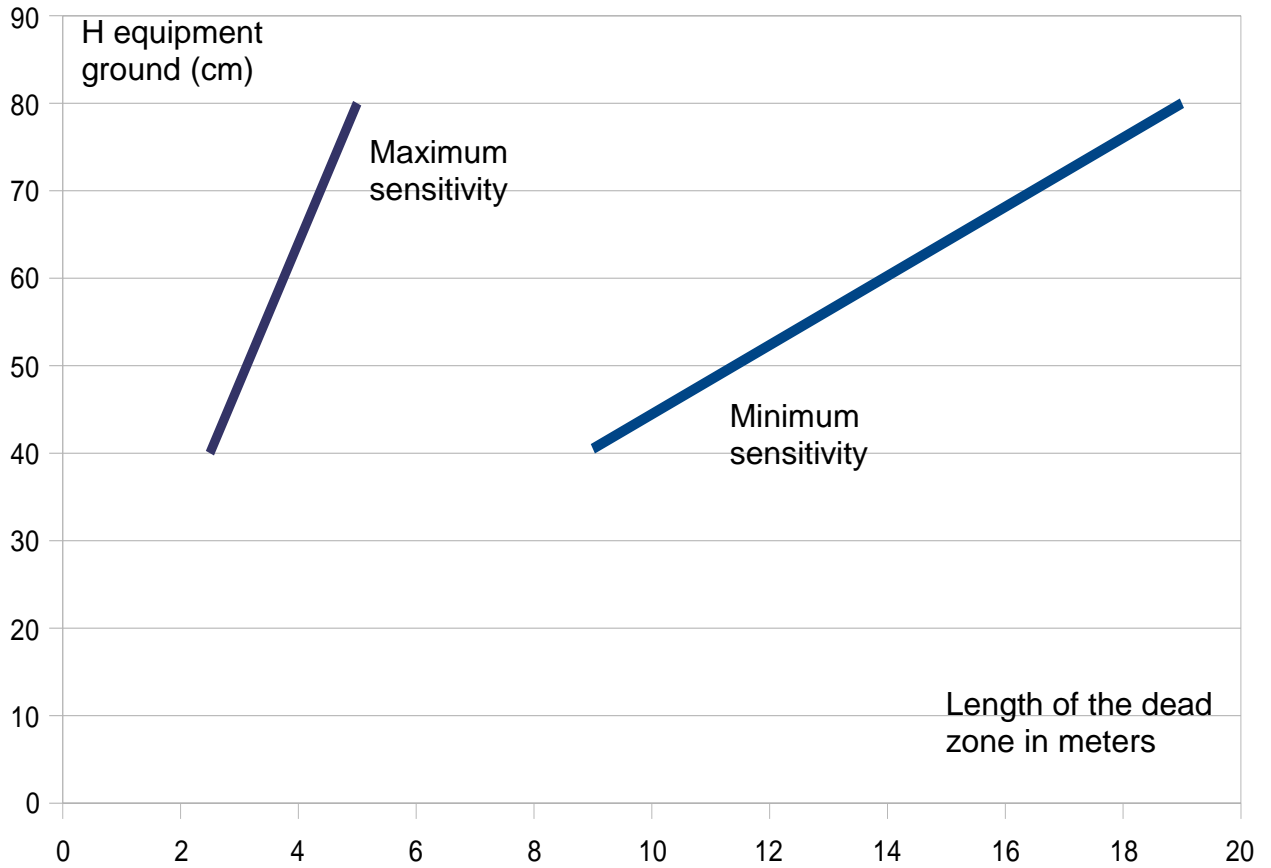

# Operation Mode

---

- **Column Transmitter:**

After you remove the cover and shield, make connections to the mains power transformer and tamper circuit.

1. Check the various connections: the power transformer to the circuit, the battery, the power circuit to circuit and transmitter cavities TX (See pp. 9, 12-13).
2. Power board, check the LED lights on Mains power adapter and three power LEDs with V-Test jumper inserted in position 1-2 (see pp. 12-13).
3. Turn OFF the switch which is on cavity TX. (See page 14).
4. Verify that is in position ON one of the four switches of the "channel selector" tab, TX (same as RX) See page. 9.
5. Insert the jumper in position 2-3 to verify that LEDs output and VCC (see page 10).
6. Replace the two jumpers in the resting position.

- **Column Receiver:**

After you remove the cover and shield, make connections to the mains power transformer and tamper circuit.

1. Check the various connections: the power transformer to the circuit, the battery, the power circuit to circuit and transmitter cavities RX (Vedi pagg. 10-13).
2. Power board, check the LED lights on Mains power adapter and three power LEDs with V-Test jumper inserted in position 1-2 (Vedi pagg. 12-13).
3. Turn OFF the switch which is on cavity RX.(Vedi Pag.14).
4. Verify that is in position ON one of the four switches of the "channel selector" tab(same as TX) (Vedi pagg. 10-11).
5. Check the "voltages" on the receiver, turning in ON position the switch N.10 "selector function", and displaying the desired tension (5, 9, 13.8 volts) with dip No 7-8-9 (See pp. 11-12).

***Perform an initial visual alignment between the two columns (TX and RX).***

**Horizontal orientation:** Loosen the screws and turn the column.

**Vertical orientation:** Loosen the screws of the handling system of the parable, and rotate.

**Verify that on the board RX the leds alarm and Channel are on. Otherwise proceed with the electronic alignment, however, be made to obtain a precise alignment.**

### ***Electronic alignment.***

- 1. Turn ON the dip of the "Selector Function" numbers 1,2 and 3, leaving all others to OFF.**

**Align horizontally and vertically then the parable of the receiver for maximum signal seen on "Led test alignment".**

**If the signal is too strong or too weak to act on the knob of the "gain" so that only the first four LEDs light up red.**

**Rerun the orientation of the parabola RX. Once the maximum orientate the parable TX.**

- 2. Goodness signal: Turn OFF the switching of the "selector functions" 1 and 2 and ON the numbers 3,5 and 10 for the Voltmeter display the gain value. The optimal values are between 4.5 and 6.5 volts.**
- 3. AGC: position ON the switches numbers 1 and 2 of the "Selector Function", leaving all others to OFF. Check after about a minute that the 4 LEDs are lit red and 2 yellow LEDs for "Led test alignment",too.**
- 4. Verify that on the board RX the leds alarm and Channel are on. Otherwise proceed with the electronic alignment.**

### ***Walk Test To check the "sensitive area".***

- 1. Turn the knobs "sensitivity" and "Delay" to the minimum and reposition to  $\frac{1}{4}$  of winder.**
- 2. Turn ON the microswitch of the "selector function" Number 4 leaving all others to OFF. This operation is inserted to signal the buzzer will sound continuously when there is an alarm (see pp. 11, 12), while with a variable sound intermittently when in a sensitive area.**

3. In the absence of disturbance signal, turn the potentiometer Walk Test to the point where you hear no sound.
4. Approaching the center of the cone of the sensitive area, the buzzer there evidence of an intermittent sound. The sensitive area is represented by the graph on page 17.
5. Test of the acrossing, making sure the intermittent sound of the buzzer and then the long beep and shutdown "LED Alarm" column on the Rx.

### ***Sensitivity.***

The sensitivity adjustment potentiometer (see page. 11, 12) affects the alert threshold, the "sensitive area" (see p.17) and "dead zone" (see p. 18). NB sensitivity too high can cause false alarms, conversely a too low can prevent the detection of the small intruders.

Turn ON the dips of the "selector function" Numbers 6 and 10, leaving all others to OFF. In this manner is displayed on the Voltmeter sensitivity value. Note that small values indicate a higher value of sensitivity:

0V=maximum sensitivity  
9V=minimum sensitivity

Calibration is performed taking into account the user requirements.

*Example:* the system should not go into alarm when it is crossed by an animal of a certain size. Keep in mind that high sensitivity can generate false alarms.

### ***Delay.***

The potentiometer adjustment of the delay (see page. 11, 12) affect the crossing speed. To verify the delay is necessary to experiment crossing at reduced speed. Remember that setting too high or low could cause false alarms

## Technical specification

---

“MW” frequency	24 Ghz in K band		
Max range	250 m		
Power supply	220V		
Absorption for pair	Max at 230V 158Watt		
Operating temperature	- 25°C / + 65°C (Available KIT heaters for lower temperature operation up to -50°)		
“MW” channel	4 Exchangeable		
Modulation	ON-OFF		
Sensibility adjustment	Trimmer.		
Delay adjustment	Trimmer.		
Dimensions:	Height from 100 to 300 cm	Width 25 cm	Deepness 20 cm
Weight	From 10 to 20 kg for barrier		
Alignment	Eletronic with instruments on motherboard		
Outputs	Alarm relay and Tamper		



Via Adda 66/68 – 20882 – Bellusco (MB) – Italia  
 Tel. + 39.(0)39.6883019 r.a. – Fax + 39.(0)39.6200471  
[www.politecsrl.it](http://www.politecsrl.it) - E mail: info@politecsrl.it