



# MANA IR SMA

Infrared barrier for perimeter  
protection range 250 m

SMA technology  
and RS485 output.

Installation Manual.

## INDEX

<b>1</b>	<b>LIST OF MAIN COMPONENT</b>	<b>Pag. 3</b>
<b>2</b>	<b>ASSEMBLING AND POSITION THE CAMBLE PIT</b>	<b>Pag. 4</b>
<b>3</b>	<b>TRANSFORMER MOUNTING</b>	<b>Pag. 6</b>
<b>4</b>	<b>SUPPLY CONNECTION</b>	<b>Pag. 8</b>
<b>5</b>	<b>CABLES AND CABLING</b>	<b>Pag. 9</b>
	CONNECTION TO THE BOARD MES9C	<b>Pag. 10</b>
	CONNECTION AND SETTING HEATHERS	<b>Pag. 11</b>
	SYNCRONISM CONNECTION	<b>Pag. 12</b>
	SERIAL CONNECTION TO ADEBUS	<b>Pag. 13</b>
	CONNECTION TO SERIAL PORT FOR EACH COLUMN	<b>Pag. 13</b>
<b>6</b>	<b>OPTICAL CONFIGURATION</b>	<b>Pag. 14</b>
	OPTICAL TX	<b>Pag. 14</b>
	OPTICAL RX	<b>Pag. 15</b>
	3 RX/TX SETTING	<b>Pag. 16</b>
	2 RX/TX SETTING	<b>Pag. 16</b>
<b>7</b>	<b>COLUMN ALIGNEMENT</b>	<b>Pag. 17</b>
<b>8</b>	<b>CALIBRATION THROUGH SMA SYSTEM</b>	<b>Pag. 18</b>
<b>9</b>	<b>CALIBRATION WITH PARALLEL BEAMS</b>	<b>Pag. 21</b>
<b>10</b>	<b>CALIBRATION WITH CROSSED BEAMS</b>	<b>Pag. 22</b>
<b>11</b>	<b>SETTING AND PROGRAMMING MOTHER BOARD ( MES 9012)</b>	<b>Pag. 23</b>
<b>12</b>	<b>LED FUNCTION</b>	<b>Pag. 24</b>
<b>12</b>	<b>CHARACTERISTICS AND DIP SWITCH ES SET</b>	<b>Pag. 25</b>
	RESPONSE TIME ADJUSTMENT	<b>Pag. 26</b>
<b>14</b>	<b>TECHNICAL CHARACTERISTICS</b>	<b>Pag. 27</b>

### ***NB: Installation reccomendations***

- Once installed, you must ensure that the barrier is perfectly closed through its tight lids.
- Use the supplied cable gland for the lower input cables. Not using appropriate accessories will invalidate the degree of protection (IP).

# 1. LIST OF MAIN COMPONENTS

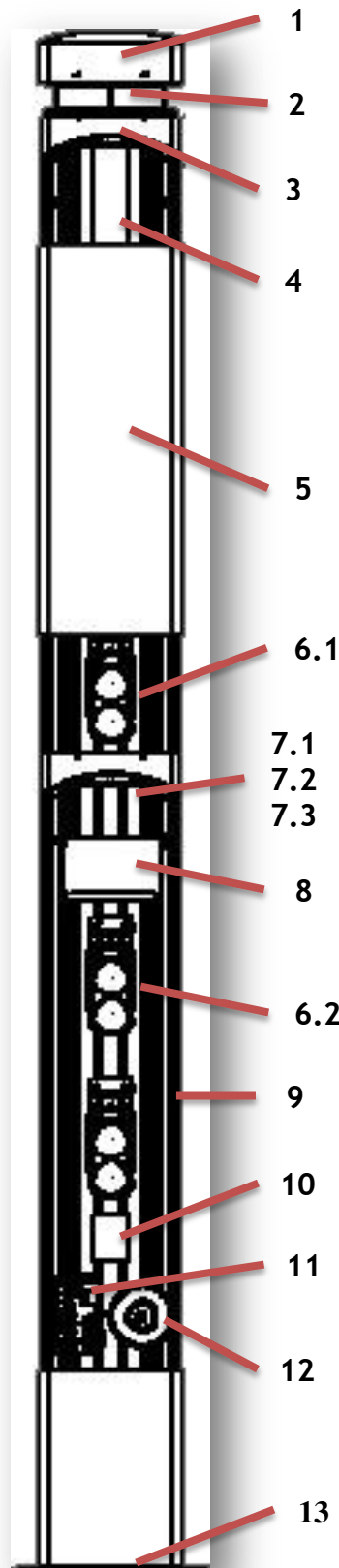

## N° Description

<b>1</b>	Upper cover
<b>2</b>	Anti climbing cover (optional)
<b>3</b>	Double Tamper
<b>4</b>	Motherboard SMA
<b>5</b>	Black polycarbonate front cover
<b>6.1</b>	TX Optical
<b>6.2</b>	RX Optical
<b>7.1</b>	Flat cable 20 poles (optical connection)
<b>7.2</b>	Flat cable 20 poles (MES9012 to MES9C)
<b>7.3</b>	Flat cable 8 poles BUS (MES9012 a MES9C)
<b>8</b>	7 Ah battery support (optional)
<b>9</b>	Aluminum profile
<b>10</b>	Terminal board SMA
<b>11</b>	Supply card 12Vcc/24Vac
<b>12</b>	Mana transformer 160 VA
<b>13</b>	Aluminum base.

## 2. ASSEMBLING AND POSITIONING THE CABLE PIT

The cable pit has two functions; the first is to permit easy connection of all the cable ducting and conduit and secondly as a hold solid base to mount the beam tower.

Use the supplied nuts and bolts to assemble the cable pit.

Overlap the right-hand edge of one side pan to the left-hand edge of the next.



Assembled cable pit, ensure that the mounting flange is uppermost.

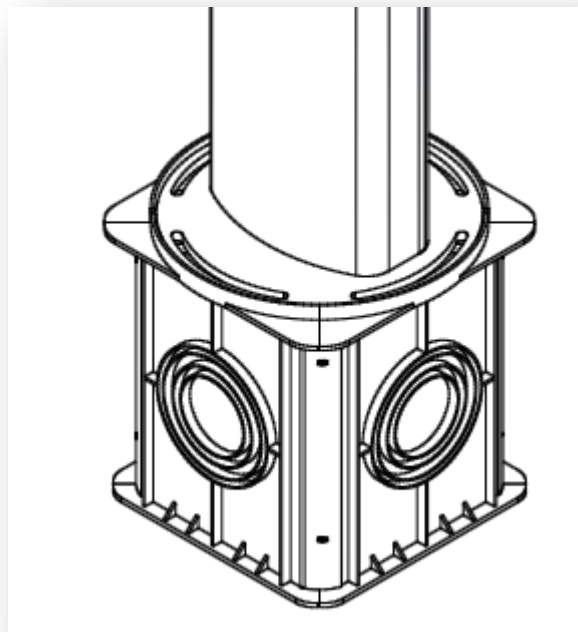

Once fully assembled the cable pit is installed ten centimeters below ground level and is embedded in concrete; once correctly installed it can be covered (with turf or suitable decking) so that only the IR beam tower is visible .

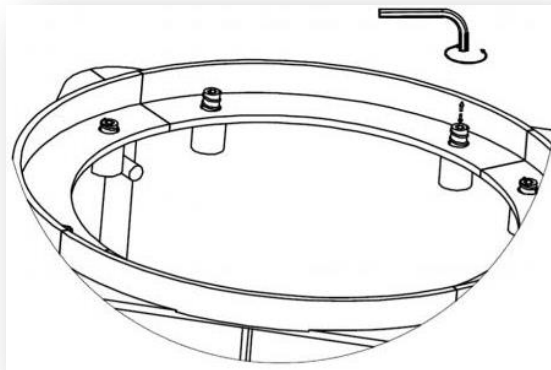
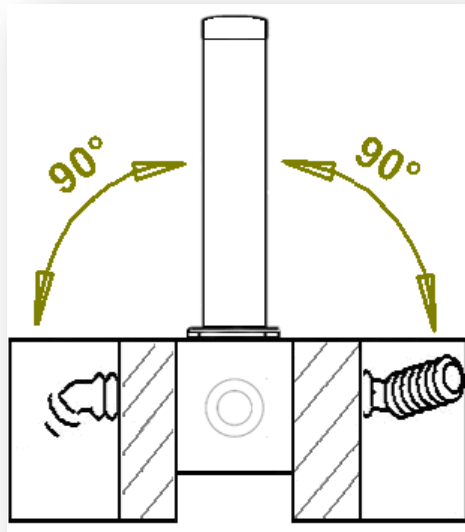

**REGULATION  
EXAMPLE**

### 3. TRANSFORMER MOUNTING

Kit compodes by:

- 1 transformer 160VA with 2 output;
- 1 screw 8x60;
- 2 nut M8;
- 1 perforated plate;
- 1 plate;
- 2 black sheath insulating;
- 4 anchor screw barrier.

Move the screw 60mm, as shown in the figure, in the perforated plate and screw the bolt lock.

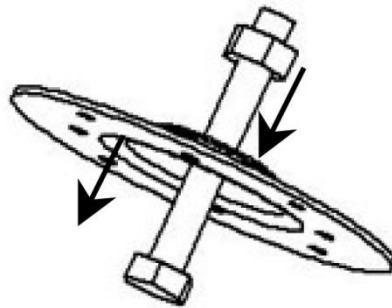

Place the plate in the cavity, especially left, so you can screw tighten the screws to the column and have enough space for the battery. Screw the 4 screws

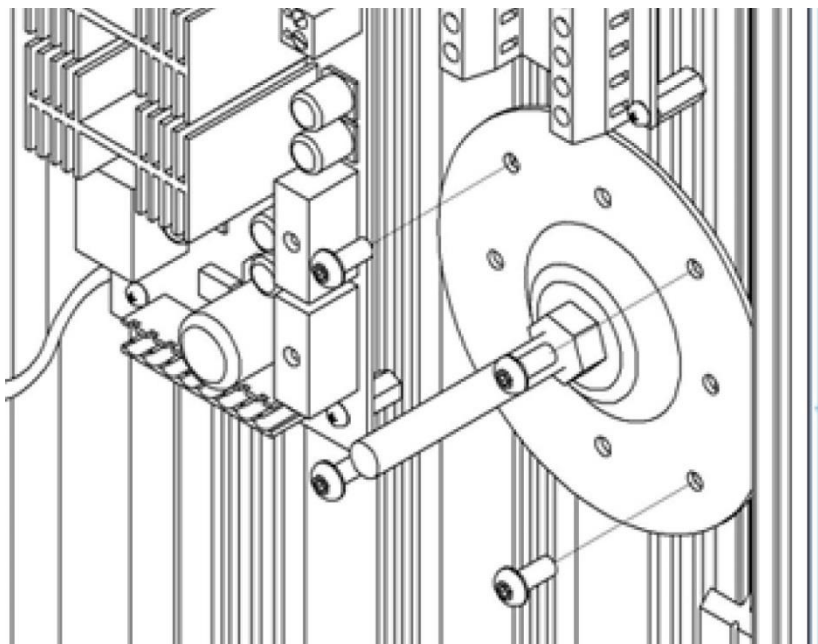

Insert the sheath, the transformer then again the sheath and plate and fix everything with the nut.  
Follow the wiring instruction in the manual.

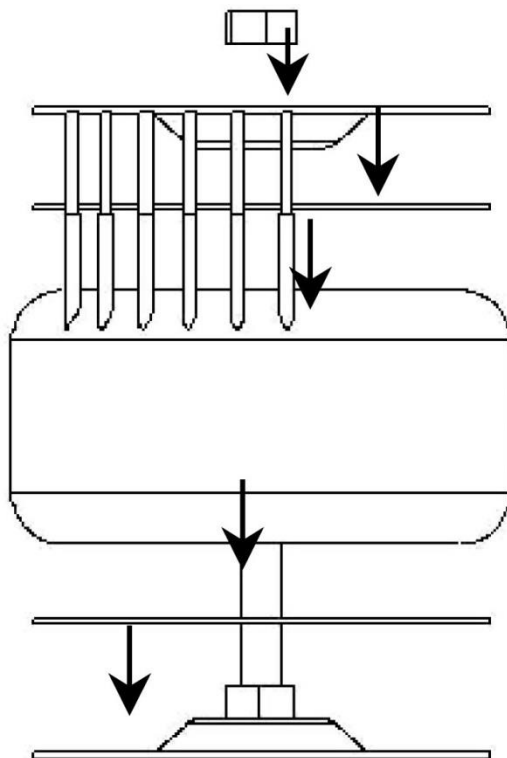

#### Recommended placement in the barrier

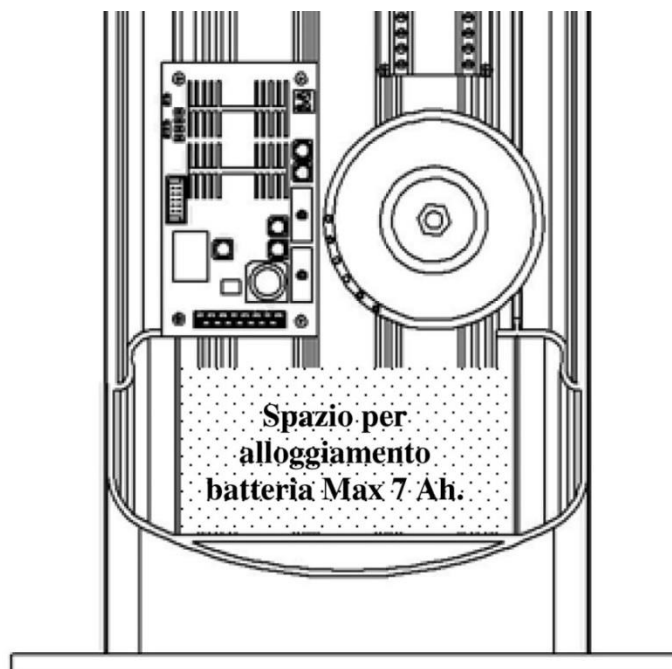





## 5. CABLES AND CABLING

The wiring requires to SEPARATE the power cable 12Vdc (ex. 2x0.5 + Nx0.22), to the power cable for heaters 24Vac (ex. 2x0.75) to prevent input of disorders of the AC voltage on the barrier.

**N.B. is absolutely necessary to shield the cable that provides 12 Vdc power supply and put the metal braid to ground.**

The cable size depends on the consumption of the columns and the resistance of the cable to the distances involved.



**Cable 230Vac (culomn power)**



**Cable 12Vcc (sync + signal)**

## CONNECTION TO THE BOARD MES9C

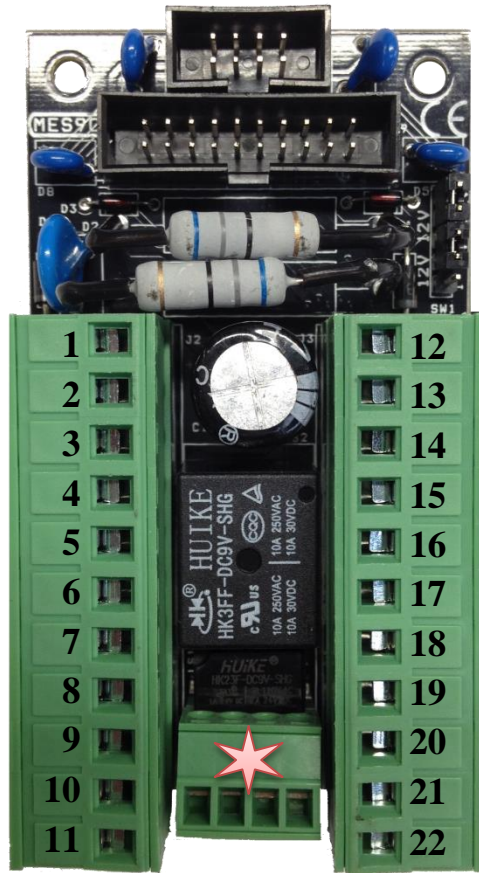

Serial connection  
ADEBUS (pag. 11)

Positive supply	+10 - 30Vdc	1	12	12/24 Vac-cc	Heaters supply
Negative supply	GND	2	13	12/24 Vac-cc	Heaters supply
Tamper output	TMP	3	14	G.IN	<b>Negative</b> input to exclude the barrier for 1 minute
Tamper output	TMP	4	15	AND	<b>+12 Vdc</b> to have AND RX1+RX2
Alarm output (NO)	NA	5	16	BEAM	<b>0V</b> to AND RANDOM
Alarm output (NC)	NC	6	17	S.LOW	<b>+12 Vcc</b> - exclude RX1
Alarm output (C)	COM	7	18	A.MASK	<b>0 V</b> - exclude RX1+RX2
Positive synchro input (TX=>RX)	+ S IN	8	19	+ S OUT	NEGATIVE OPEN COLLECTOR
Negative synchro input (TX=>RX)	- S IN	9	20	- S OUT	<b>open in case of fog</b>
Not utilized		10	21		NEGATIVE OPEN COLLECTOR
Not utilized		11	22		<b>open in case of masking</b>
					Positive synchro output (TX=>RX)
					Negative synchro output (TX=>RX)
					Not utilized
					Not utilized

**NB: DISQUALIFICATION AND ANTIMASK ARE NEGATIVE OPEN COLLECTOR OUTPUTS**

# Connection and settings heaters

The power of the heaters is by default set to 24 V (ac or dc), but you can set it to 12 VDC repositioning the jumper on MES9C and on each optical as shown.

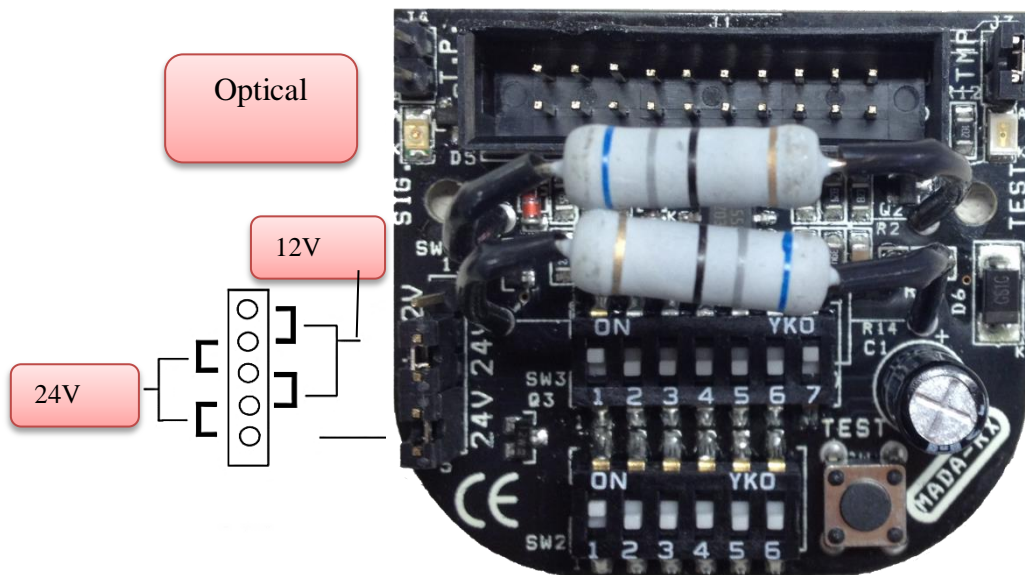
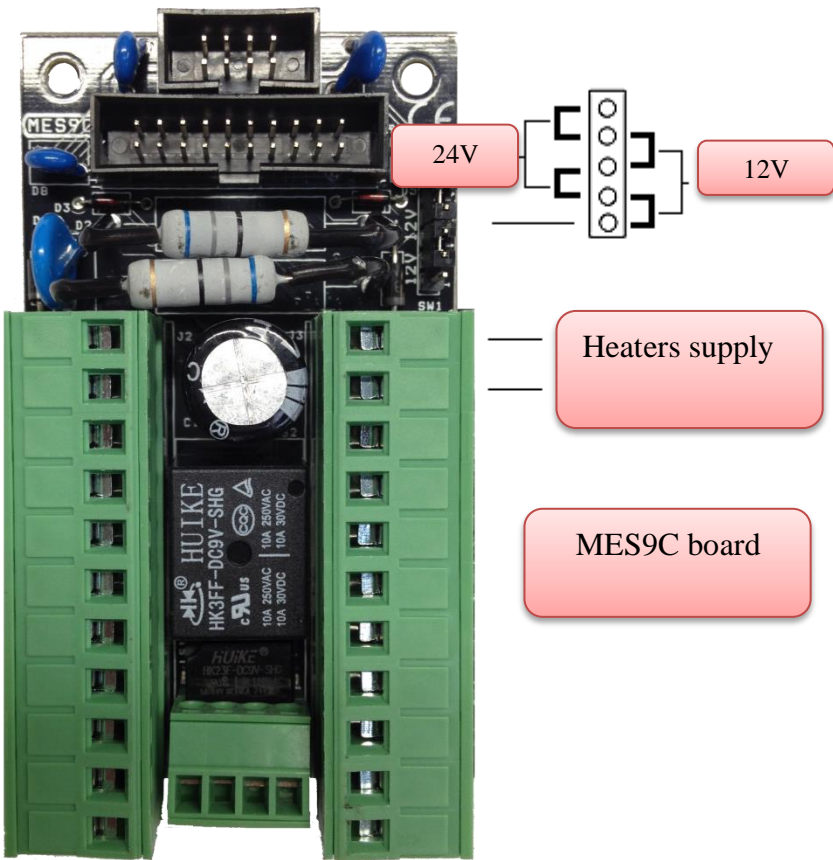

## Synchronism connection

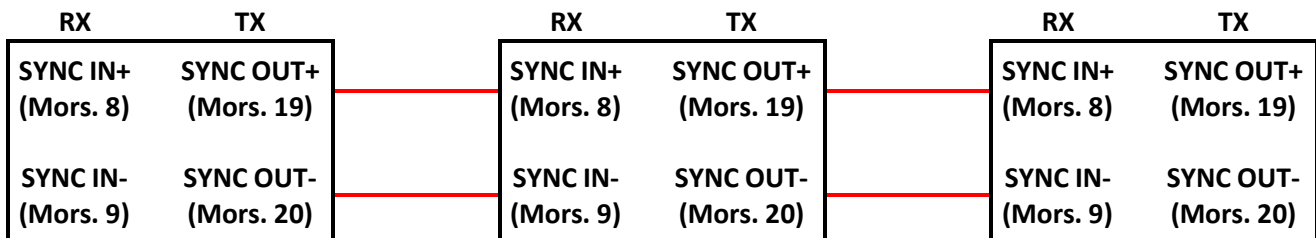
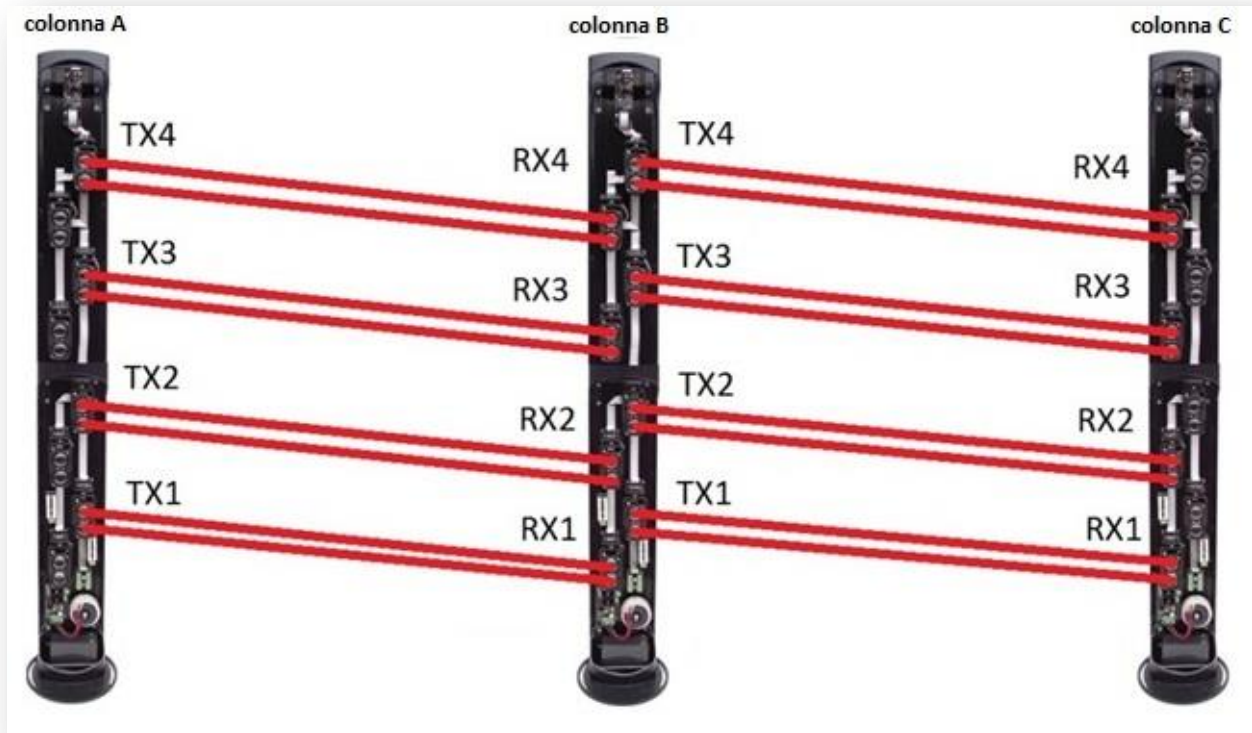

The synchronisms have to be connected according to the diagram above, the **Sync out** corresponds to the TX part of the column and will have to be connected to the **Sync in** on the RX opposite one. You must also connect the negative power supply, shared between the columns, so it is appropriate to use a shielded cable alarm, 2X0, 22 to connect the sync and the screens to negative Vdc of power supply board for both columns.

## Serial connection to ADEBUS

Each column can be connected via the RS485 bus to the control panel ADEBUS for planning, monitoring and managing local or remote system.  
 For more information, refer to "Installation Manual Adebuss & AdebussExplorer"

### Connection to serial port for each column

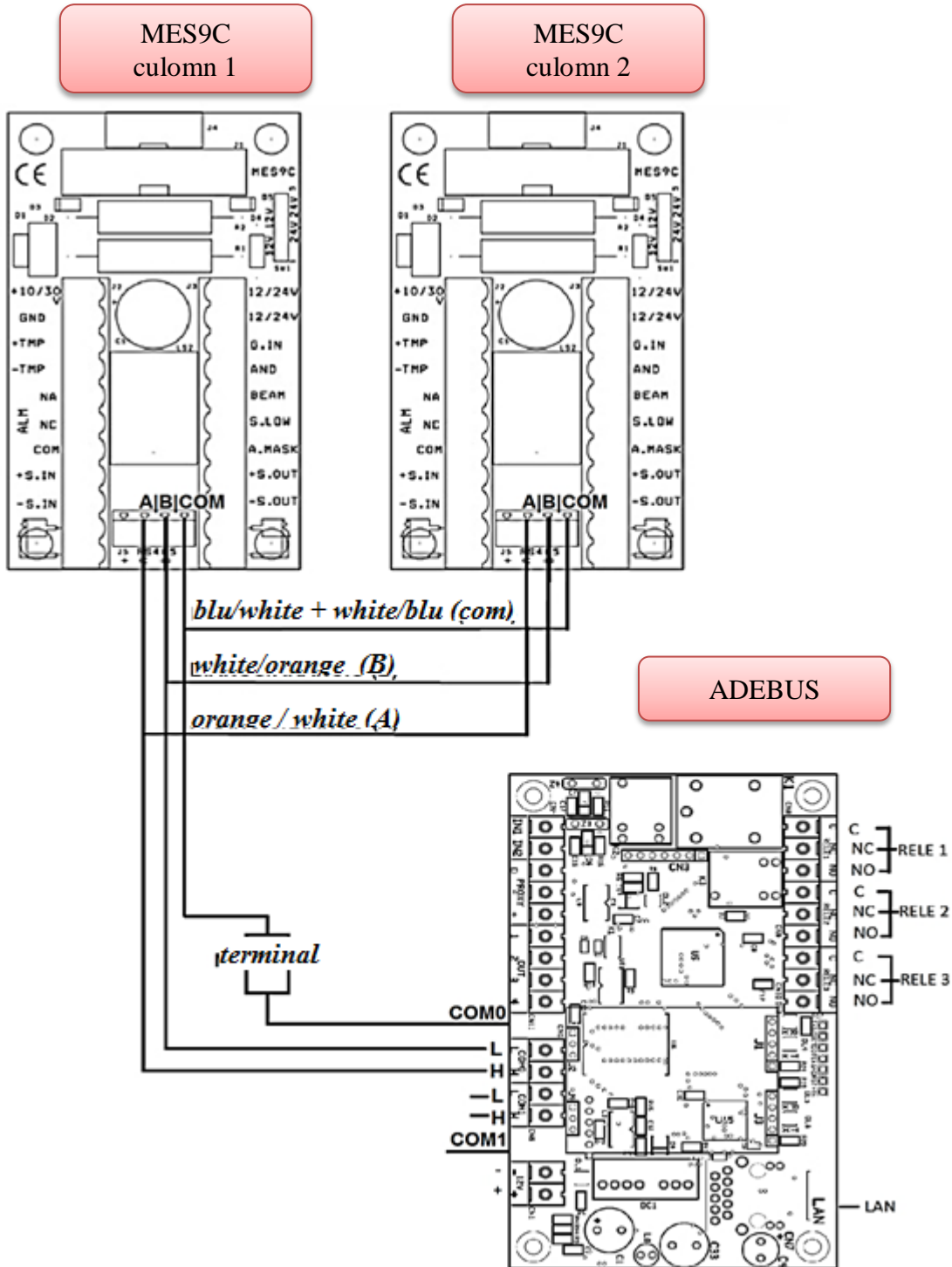



# 6. OPTICAL CONFIGURATION

## OPTICAL TX

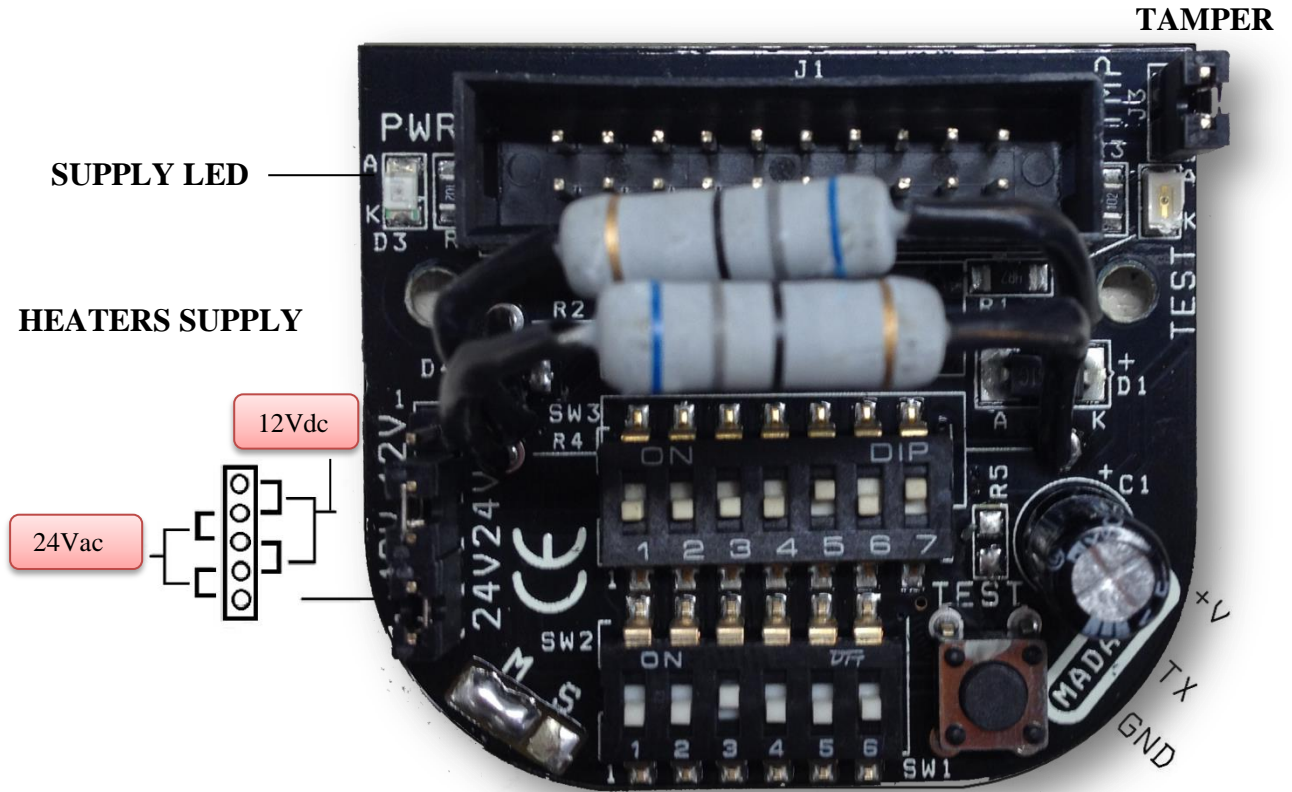

	1	2	3	4	5	6	7	1	2	3	4	5	6	
<b>TX1</b>	Black	Black	Black	Black	Black	Black	Black	Black	White	Black	White	Black	White	ON
<b>TX2</b>	Black	Black	Black	Black	Black	Black	Black	Black	White	Black	White	Black	White	ON
<b>TX3</b>	Black	Black	Black	Black	White	Black	Black	Black	White	Black	White	Black	White	ON
<b>TX4</b>	Black	Black	Black	Black	White	Black	Black	Black	White	Black	White	Black	White	ON

**NB:** The settings relating to addresses are already set to Default.

# OPTICAL RX

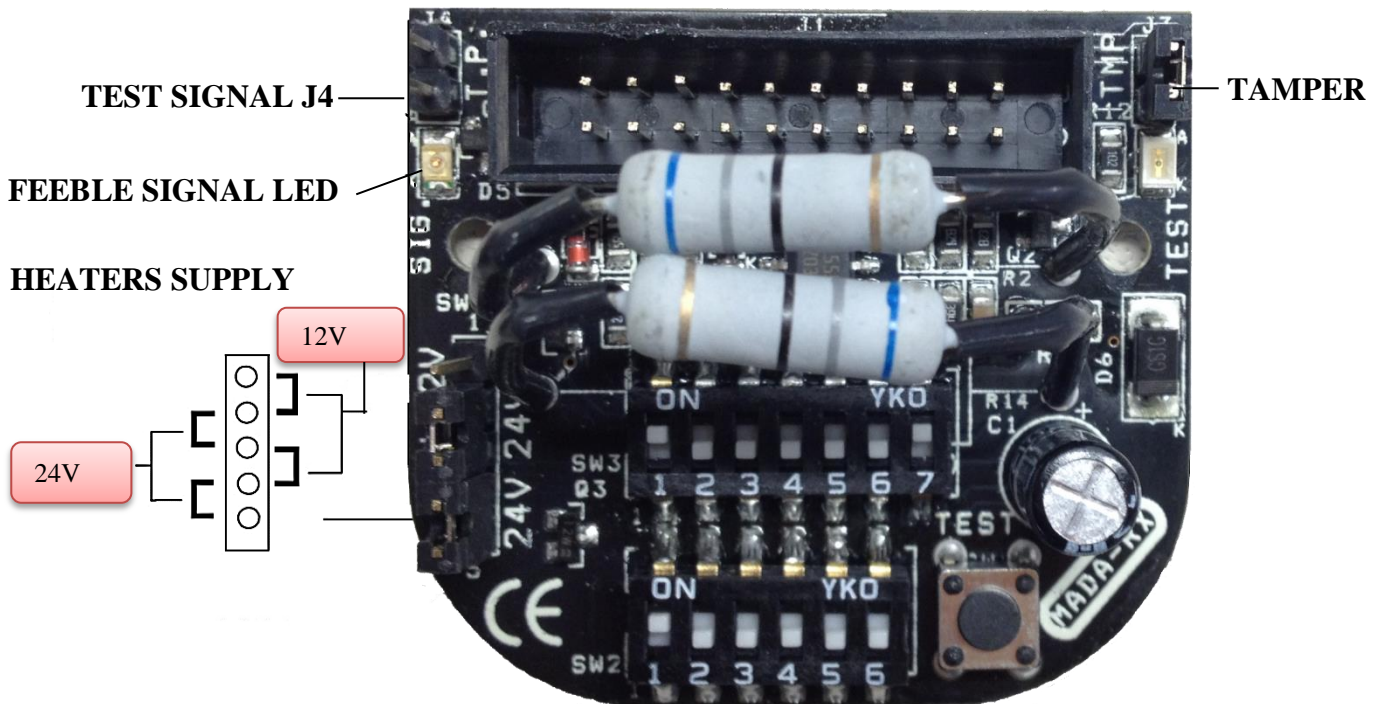

	1	2	3	4	5	6	7	1	2	3	4	5	6	
<b>RX1</b>														ON
<b>RX2</b>														ON
<b>RX3</b>														ON
<b>RX4</b>														ON

**NB:** The settings relating to addresses are already set to Default.

## 3 RX/TX SETTINGS

The setting of the DIP SWITCHES on the lenses is set:

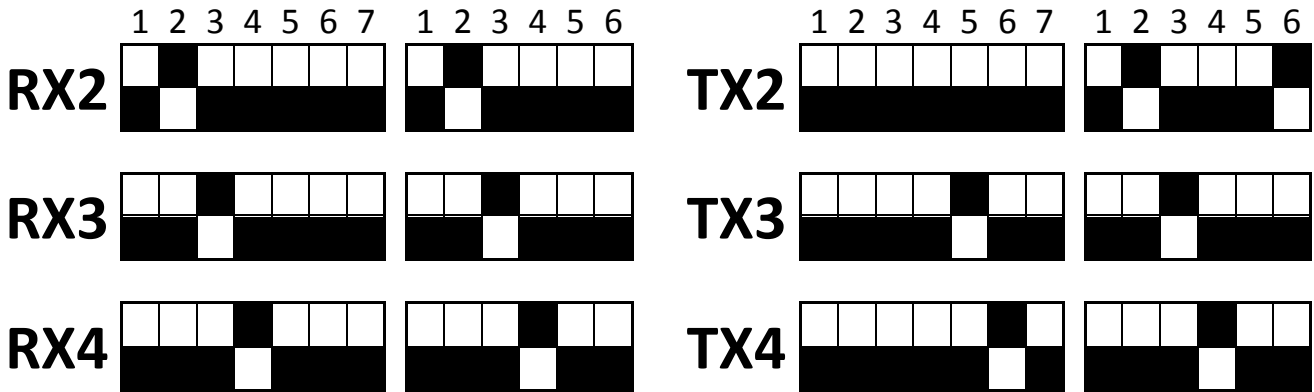

It should be set to ON the DIP on the motherboard RX exclusion 1

## 2 RX/TX SETTINGS

The setting of the DIP SWITCHES on the lenses is set:

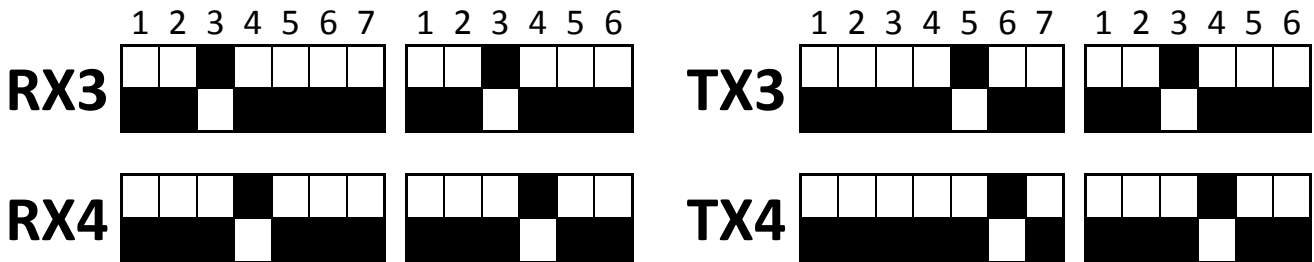

It should be set to ON the DIP on the motherboard RX exclusion 1 + 2



## 7. COLUMN ALIGNEMENT

For proper alignment, once the barriers are installed, orient the optical of transmitters and receivers in the direction of each other by adjusting the lens holder horizontally through the manual movement after loosening the locking screw on the joint, and vertically through the front screw on the left side of the lens.

### Vertical adjustment

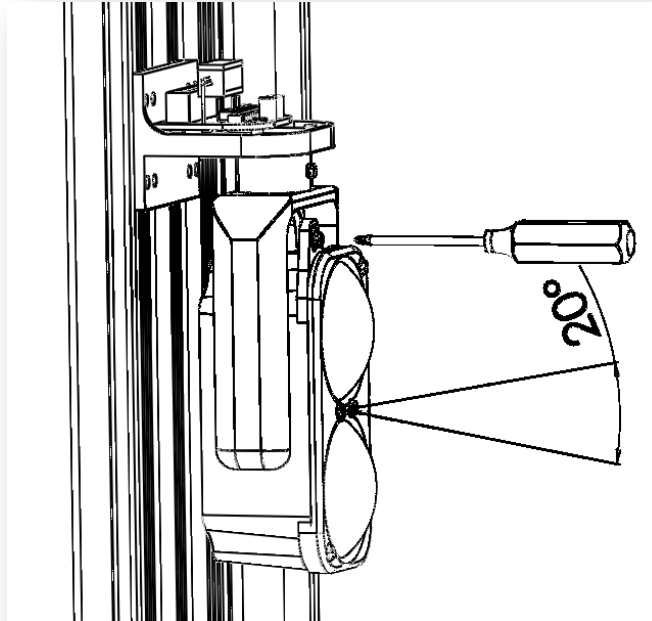

### Horizontal adjustment

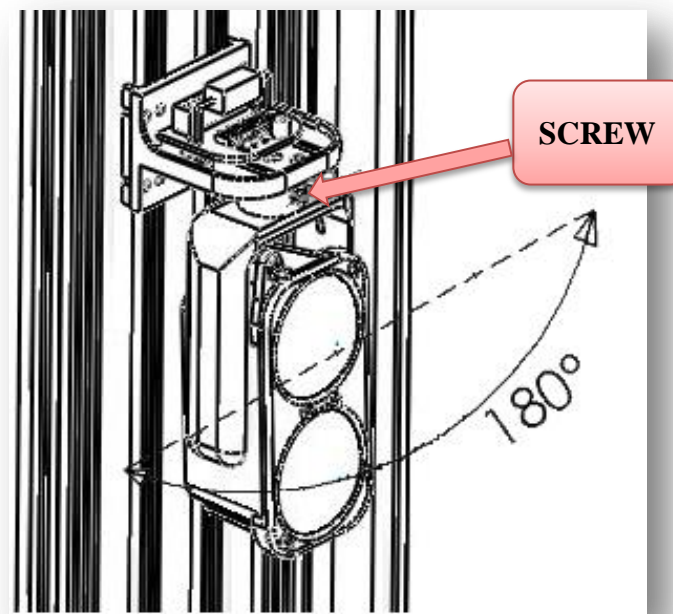

**N.B.: FASTEN THE UNLOCKING SCREW AFTER THE ADJUSTMENT**

## 8. CALIBRATION THROUGH SMA SYSTEM

- 1) Start the alignment of the transmitter is on the barrier by checking the position of the DIP switch 7 to ON and activating the TEST optics TX (1 or 2 or 3 or 4), by pressing the dedicated button for about 3 seconds until the orange LED TEST will lit up.

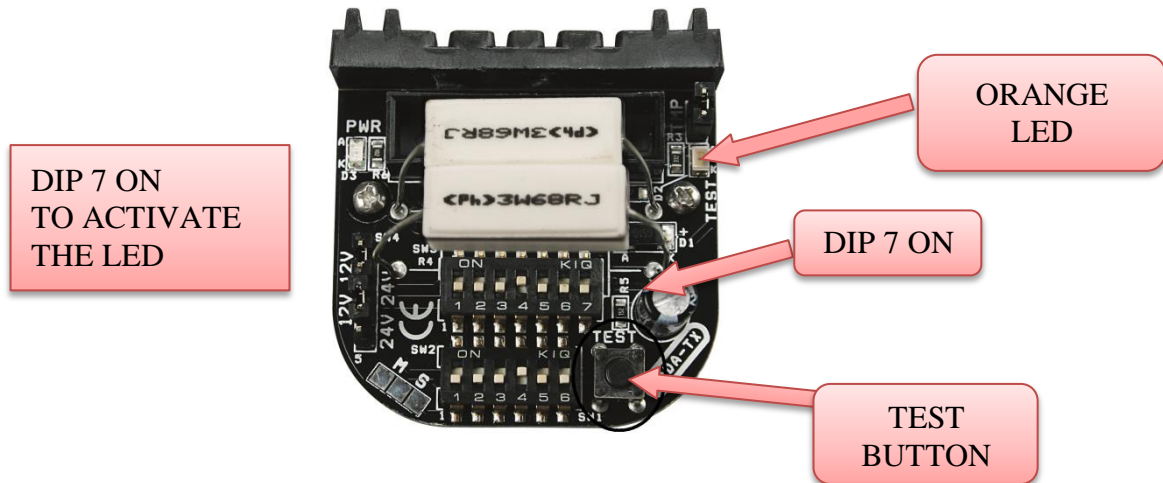

- 2) Place in the corresponding optical TEST (1 or 2 or 3 or 4) on coral receiver, checking the position of the DIP switch 7 to ON and pressing the dedicated button for 3 seconds until the BUZZER and the LED TEST turns ON, (with high brightness)

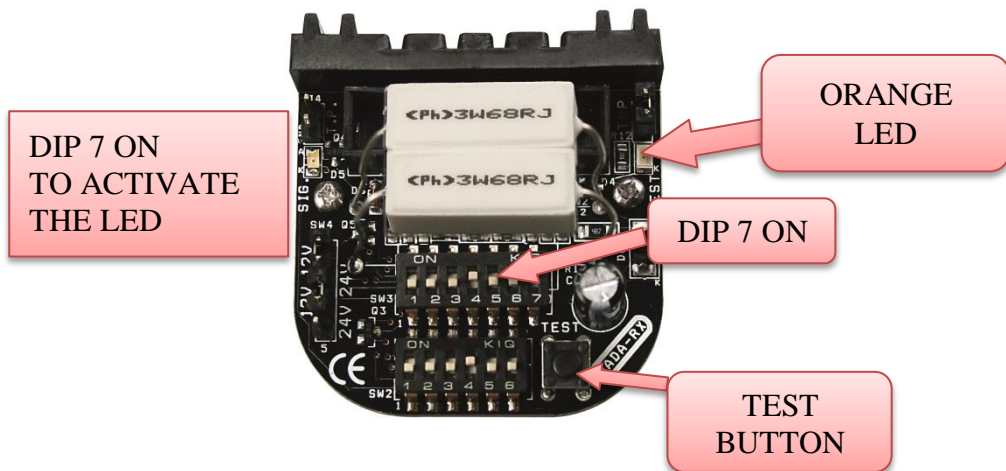

- 3) Place the filter in front of the optic Transmitter you are aligning.  
It is recommended that the calibration with the use of the filter over long distances and then search for the maximum signal.

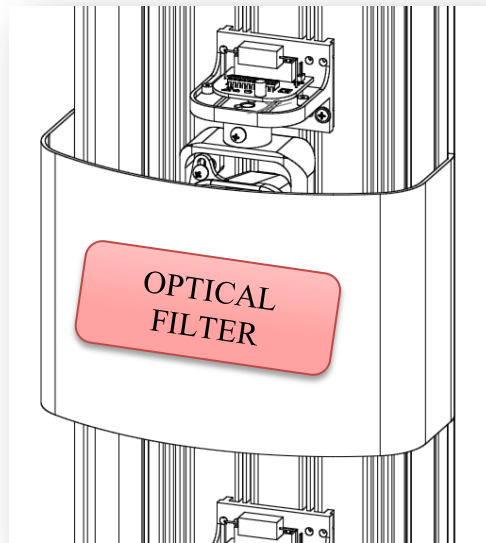

- 4) Through the TRANSMITTER lens shifts, find the maximum optical alignment based on the Buzzer and LEDs (with high brightness), the increase in the frequency of flashing (until the LEDs is fix on and the whistle of the corresponding BUZZER) indicate a better ALIGNMENT.



- 5) With a FULL rotation on the horizontal RX lens, is carried out the SCANNING of the optical signal.

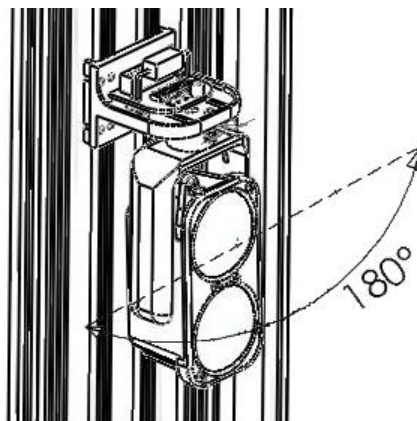

- 6) Rotating the lens RX find the maximum value of ALIGNMENT corresponding to the LEDs (with high brightness) FIXED and the whistle of the BUZZER CONTINUOUS.

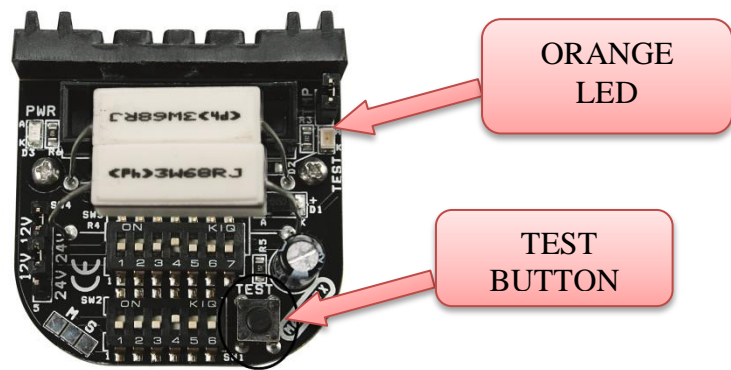

- 7) Exit the function of by repressing the ALIGNMENT TEST button for about 3 seconds on both optics (TX-RX) making sure that the orange LED TEST is shown in original condition.
- 8) Set the DIP switch 7 to OFF to ALL OPTICAL if you want to turn off the LEDs.



**NB:** you can SEE the calibration value through the multimeter on each optical receiver. For this procedure, you must have the pair of lenses (TX-RX) in TEST.

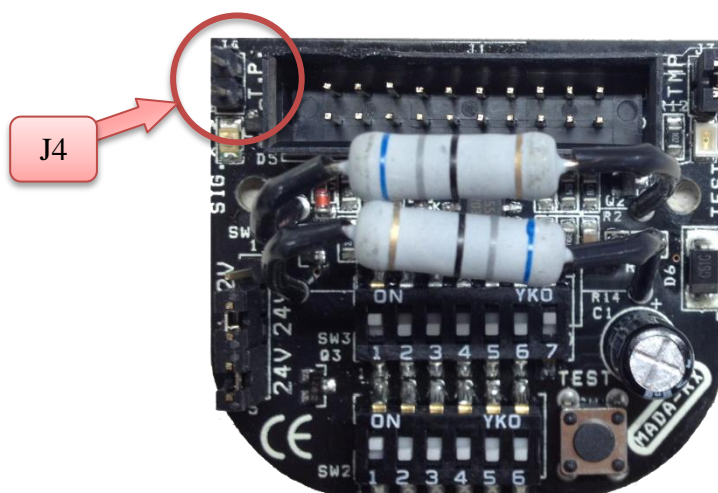

## 9. CALIBRATION WITH PARALLEL BEAMS

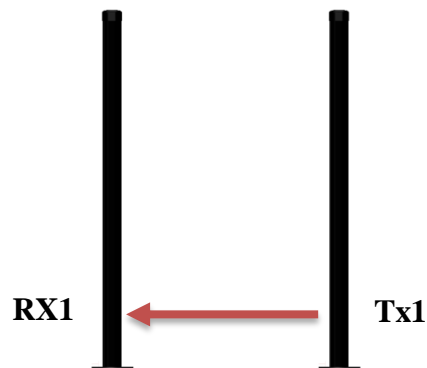

- 1) Put in test the optical TX1 and RX1 (if present see p.11-12) and proceed with the calibration as explained

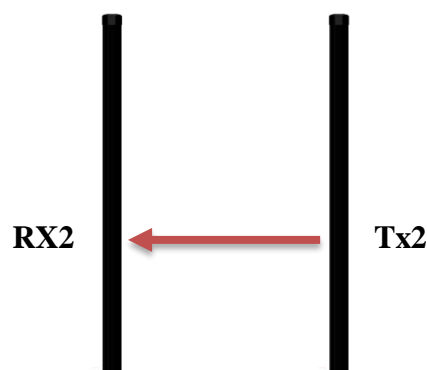

- 2) Put in test the optical TX2 and RX2 (if present see p.11-12) and proceed with the calibration as explained

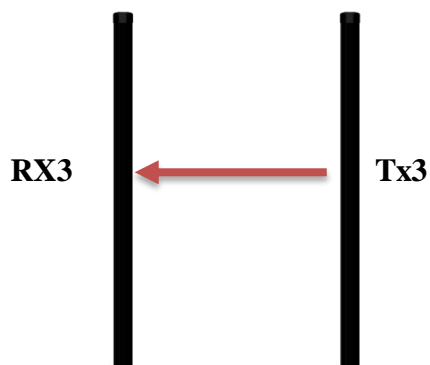

- 3) Put in test the optical TX3 and RX3 and proceed with the calibration as explained

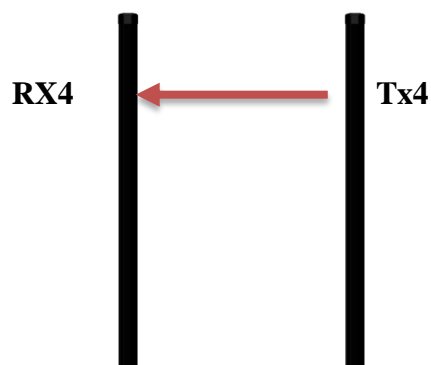

- 4) Put in test the optical TX4 and RX4 and proceed with the calibration as explained

**N.B.:** during the testing phase of an optical transmitter the other TX not in test are switched off automatically.

## 10. CALIBRATION WITH CROSSED BEAMS

Per attivare la funzione spostare il DIP n. 2 del banco dei 12 DIPSWITCH della MES9012 in ON.

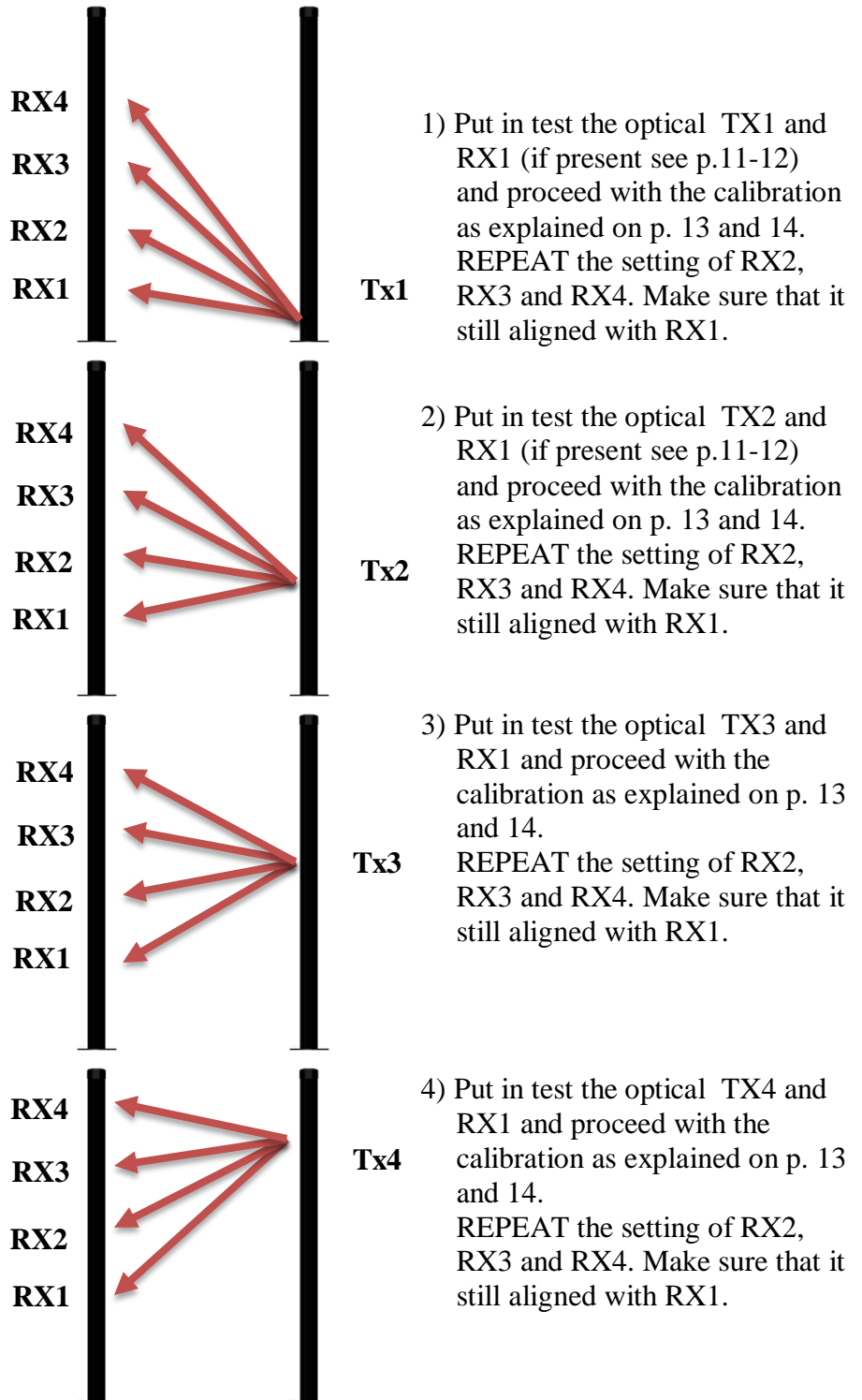
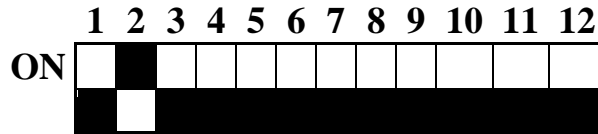



# 11. SETTING AND PROGRAMMING MOTHER BOARD (MES 9012)

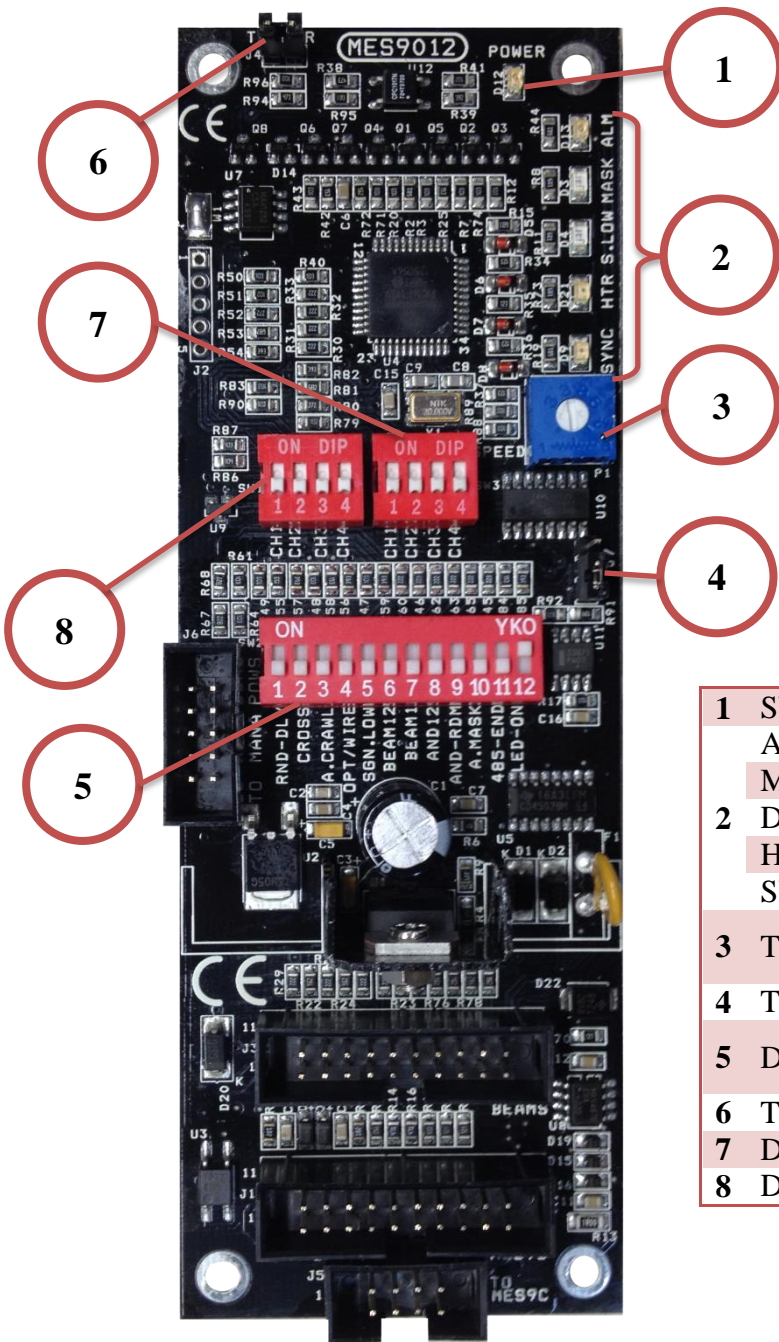

1	SUPPLY LED	Red
	ALARM LED	ALM Red
	MASKING LED	MASK Green
2	DISQ. LED	S.LOW Green
	HEATINGS LED	HTR Yellow
	SYNCHRONISM	SYNC Yellow
3	TRIMMER	Response time adjustment
4	TEST	J7
5	DIP SWITCH 12	Function selector (pag. 23)
6	TAMPER	
7	DIP SWITCH TX	
8	DIP SWITCH RX	

## 12. LED FUNCTIONNING

The motherboard has six LED signaling and control, which can be activated via the dip switches 12 on the board MES9012S dedicated in the ON position.

It is recommended that at the end of the testing set dip switches in the OFF position, both to avoid a glimpse of the signals, both to reduce consumption of the system.

<p><b>POWER</b> <i>Supply led</i></p>	<p>The SUPPLY LED is the only one to always be on in normal conditions of operation, confirm that the card is properly powered.</p>
<p><b>LED ALM</b> <i>Alarm led</i></p>	<p>Normally off, in the event of ignition, indicates the alarm status. The alarm condition will depend on the setting of the jumpers composing the board and the delay time set on trimmer SPEED will be adjusted from a minimum of 50 msec to 500 msec. Increasing clockwise.</p>
<p><b>LED MASK</b> <i>Signals of Masking</i></p>	<p>The ignition of the MASK LED indicates the presence of an infrared signal modulated not desired. On the terminal, in the presence of an attempt to blindness, it can obtain the signaling ANTIMASK (OPEN COLLECTOR NEGATIVE). <b>N.B.:</b> In normal operation the LED should be OFF. In the event that is either on or flashing check the setting of the jumpers for selecting beam on the various transmitters.</p>
<p><b>LED SIG LOW</b> <i>Indicates the low level of signals (fog presence)</i></p>	<p>The lighting SIG LOW LED indicates the presence of FOG INTENSE. In the presence of intense fog before having an alarm condition due to lack of signal, the LED SIG LOW lights on the terminal and you can have the message DISQUALIFICATION (OPEN COLLECTOR NEGATIVE). <b>N.B.:</b> By placing the jumper SIG LOW in the ON position, and by the intervention of the disqualification is obtained the exclusion of the barrier, which will return to work as soon as the fog lifts.</p>
<p><b>LED HTR</b> <i>Indicates the heaters functioning</i></p>	<p>The automatic heating system, electronically controlled to ensure in all climatic conditions an internal temperature between 17 ° C and 22 ° C. Normally off, when turned on the heater is on.</p>
<p><b>LED SINC</b> <i>Indicates the functioning of the synchronism</i></p>	<p>The LED SINC continuously flashing indicates the proper operation and wiring of sync both outgoing and incoming.</p>



## 13. CHARACTERISTICS AND DIP SWITCHES SET

DIP SWITCH 12 DIP	
1	<p><b>RND DLY ON</b></p> <p>In the ON position the alarm from time to time is generated with a random delay varying from 0 to 1 sec This function serves to confuse and mislead the intruder who wants to identify the detection system</p>
2	<p><b>CROSSING</b></p> <p>In the ON position activates the detention Crossed beams</p>
3	<p><b>MASTER ON/OFF</b></p> <p>In the ON position it has the "normal" operation of the barrier, set to OFF mode is activated to "ANTI CRAWLING" means that the darkening of the radius RX1 (the first down) for at least 2 sec. causing the alarm condition, regardless of whether it was previously set to OR or AND.</p>
4	<p><b>SYNC</b></p> <p>Irrelevant.</p>
5	<p><b>DISQ</b></p> <p>In the ON position activates the disqualification (with at least two optics that detect a low signal).</p>
6	<p><b>BEAM OFF 1 + 2</b></p> <p>In the ON position you get the exclusion of the first two rays starting from the bottom while the remaining rays continue to operate. The function can also be programmed remotely giving a positive control on the 12V + terminal of the terminal block marked BEAM. If you want to enable this function remotely DIP6 must remain OFF.</p>
7	<p><b>BEAM OFF 1</b></p> <p>In the ON position is obtained the exclusion of the first beam in the bottom, while the remaining continue to function. The function can also be programmed remotely giving a negative command 0 V on terminal marked BEAM ON on the terminal block MES9C. If you want to enable this function remotely DIP7 must remain OFF.</p>
8	<p><b>AND 1 + 2</b></p> <p>In the ON position is obtained the AND function of the first two receivers, that is to say that both must be interrupted to generate the alarm condition, while the remaining Rx remain be alarmed individually. This configuration can be useful in the presence of tall grass or small animals. The function can also be programmed remotely giving a positive command +12V on the terminal marked AND. If you want to enable this function remotely DIP8 must remain OFF.</p>
9	<p><b>AND RND</b></p> <p>In the ON position is obtained the AND between two random Rx, ie that to have an alarm condition should always be alarmed at least two Rx among all those used. The function can also be programmed remotely giving a negative command 0 V on the terminal block labeled AND. If you want to enable this function remotely DIP9 must remain OFF.</p>
10	<p><b>ANTIMASK</b></p> <p>In the ON position the enable function ANTI MASKING (ANTIMASK) activating the output on the terminal MES9C.</p>
11	<p><b>CLOSE RS485</b></p> <p>In the ON position closes the RS485 communication. To finish you need to put in ON only the switches of the column as far as the entire line.</p>
12	<p><b>LEDS</b></p> <p>In the ON position activates the LEDs.</p>

## DIP SWITCH RX

**DISQ 1** If the disqualification is enabled on the counter 12 via DIP SWITCH DIP 5 ON, in some cases, and particular geographical areas, it may be helpful to enable DIP 1 to ON function disqualification even if only one optical RX receives a low signal

## DIP SWITCH TX

**TEST TX** By setting all the DIP to ON with jumper J7 set to TX OFF switch off all transmitters of the column; setting the jumper to ON TX transmitters are activated at high frequency in order to allow a first visual contact between the transmitter and receiver in case of difficulty great distances.  
N.B. for the correct operation of the barrier Push down all 4 DIP

# RESPONSE TIME ADJUSTMENT

There is a potentiometer to adjust the TIME OF INTERVENTION.  
In particular, you can set the barrier for the rapid alert system (cross running) or slow (cross by walk).



By adjusting the potentiometer counterclockwise to increase the trip time up to 500ms. In this condition ensures that the alarm of a person walking through the barrier, with the advantage of excluding the possibility of any false alarms (ex. animals).

Adjusting the potentiometer clockwise decreases the trip time until 50ms. In this condition ensures the alarm of a person crossing the barrier running at maximum speed.

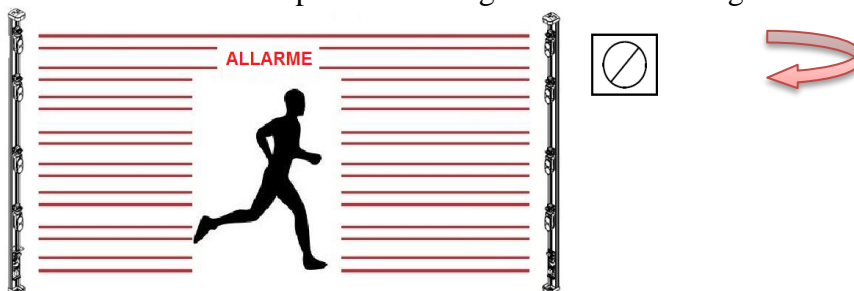

## 14. TECHNICAL CHARACTERISTICS

<b>MAX RANGE INDOOR</b>	450 m.
<b>MAX RANGE OUTDOOR</b>	250 m.
<b>SYNCHRONISM</b>	Wired
<b>OPTICAL</b>	Impulsive double lenses 950 nm
<b>DISQUALIFICATION</b>	Automatic with signaling out, open collector negative
<b>MASKING</b>	Detection of blindness by another infrared signal by signaling out, open collector negative.
<b>OPERATING TEMPERATURE</b>	- 25°C / + 65°C. Available Kit heaters for temperatures down to -50 ° C.
<b>ADJUSTMENT ANGLE</b>	± 10° vertical – 180° horizontal
<b>DETECTION OPTIONS</b>	And/Or su Rx / AND 1° e 2°.
<b>REMOtable CONTROLS</b>	AND REMOTO / AND 1° e 2° beam.
<b>PLASTIC SCREEN</b>	Specific for Infrared with HUV filter.
<b>CAP</b>	With Tamper.
<b>PROTECTION DEGREE</b>	IP 54



**POLITEC s.r.l.**

Via Adda, 66/68 - 20882 Bellusco (MB) - Italy  
tel. +39 039 6883019 r.a. - fax +39 039 6200471  
[www.politecsrl.it](http://www.politecsrl.it)