

# ALES

## 60/120

INFRARED PERIMETRAL BARRIER

DOUBLE BEAMS

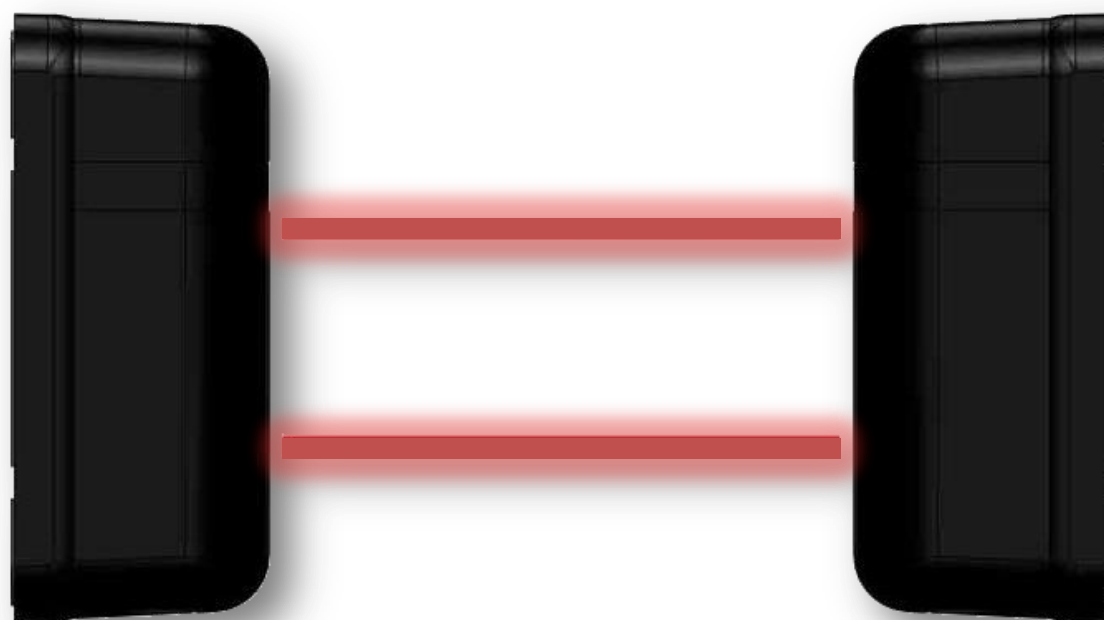

<b>1</b>	<b>MAIN COMPONENT LIST</b>	<b>Pag. 3</b>
<b>2</b>	<b>SUGGEST FOR INSTALLATION</b>	<b>Pag. 5</b>
<b>3</b>	<b>INSTALLATION</b>	<b>Pag. 6</b>
	WALL MOUNTING	<b>Pag. 6</b>
	POLE MOUNTING	<b>Pag. 6</b>
<b>4</b>	<b>CONNECTIONS AND DESCIPRIONS</b>	<b>Pag. 7</b>
	CABLE AND WIRING	<b>Pag. 7</b>
	TRASMITTER/RECEIVER	<b>Pag. 8</b>
<b>5</b>	<b>FREQUENCY SELECTION</b>	<b>Pag. 9</b>
<b>6</b>	<b>ALLIGNMENT TEST</b>	<b>Pag. 9</b>
<b>7</b>	<b>SETTING TIME</b>	<b>Pag. 11</b>
	TIME CHOICE	<b>Pag. 11</b>
<b>8</b>	<b>ENVIRONMENTAL DISQUALIFICATION</b>	<b>Pag. 13</b>
<b>9</b>	<b>ADDITIONAL TAMPER</b>	<b>Pag. 13</b>
<b>10</b>	<b>TECHNICAL FEATURES</b>	<b>Pag. 14</b>

# 1. MAIN COMPONENT LIST



1	Terminals
2	Channel selector
3	TEST button
4	Tamper Switch
5	Horizontal adjustment screw
6	Adjustment Buzzer (RX)
7	Adjustment high frequency led (RX)
8	Vertical adjustment screw
9	Lens
10	Unit base



**IR  
COVER**



**MOUNTING  
PLATE**



**“U” BRACKET  
FOR POLE  
MOUNTING**

## 2. SUGGEST FOR INSTALLATION

For proper installation of the product is necessary to remove all possible obstacles between the transmitter and receiver (trees, grass, etc..), use for the installation immovable poles or walls firmly anchored to the ground.

You should also always use cables with screen for alarm connections, proper sizing by taking more precautions due to electronic devices.

To avoid interfering with the performance and the degree of protection (IP) of the barrier is necessary to take the necessary precaution, taking care not to alter seals, plastic and mechanical parts of the product, using original accessories.

In case of repairs covered by warranty (2 years) but with obvious signs of improper installation, the Politec s.r.l. reserves the right to decide on any repair costs.

*Avoid installing the receivers beams in a position where direct sunlight, at the same angle as the receivers beams, can enter directly into optics especially at sunset and sunrise*

## 3. INSTALLATION

The barrier ALES can be installed to the wall using the mounting plate and the pole using the mounting plate and the "U" bracket (Pole Ø 48-50).

### WALL MOUNTING

1. Insert the cable alarm screen in the hole of the plate and fix to the wall with screws.
2. Pass the cable through the gasket in the base and anchor on the same plate. Make connections to the terminal.
3. Following the calibration and verification of proper operation of the system, replace the IR Cover.

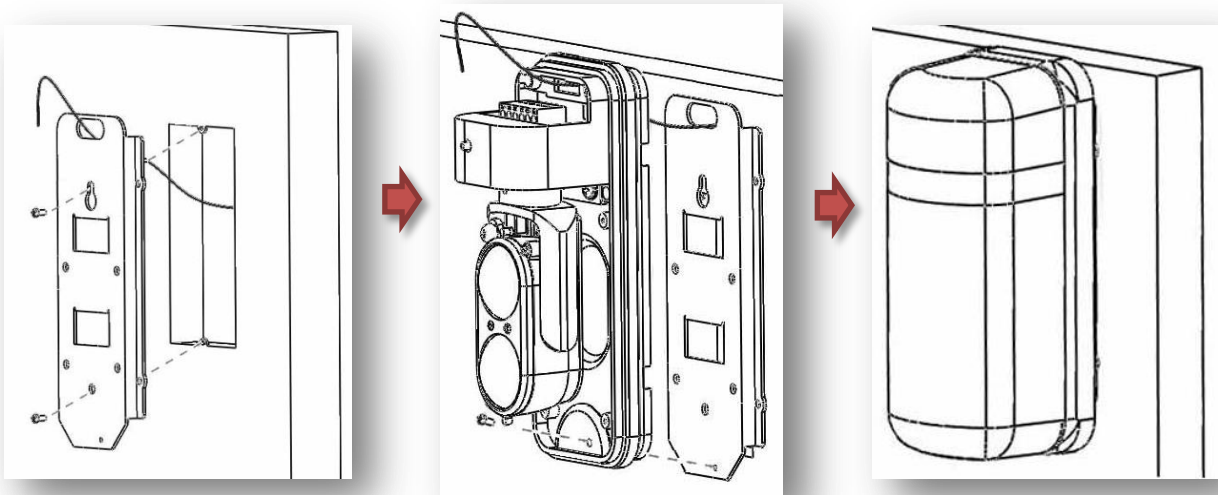

### POLE MOUNTING

1. Insert the screened cable for alarm in the hole of the plate and fix the plate to the pole using the "U" bracket.
2. Pass the cable through the gasket in the base and anchor on the same plate. Make connections to the terminal.
3. Following the calibration and verification of proper operation of the system, replace the IR Cover.

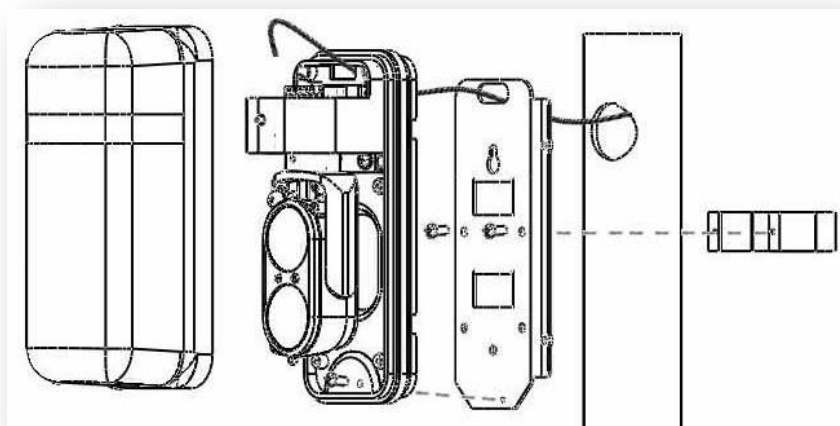

## 4. CONNECTIONS AND DESCRIPTIONS

### CABLE AND WIRING

The wiring requires the shielded power cable 12Vdc (ex. 2x0.5 + 8x0.22) with the metallic shield connected to ground to prevent the introduction of disturbances of the alternating voltage on the barrier.



The cable size depends on the consumption of the columns and the resistance of the cable

The table shows the cable cross-sections and the relative distances to ensure optimal performance using the supplied LAR22 (2-12Vdc, 5A) and a barrier ALES.

SIZE CODUCTOR	POWER SUPPLY 12Vcc
0,5 mm <sup>2</sup>	165 m
0,75 mm <sup>2</sup>	245 m
1,5 mm <sup>2</sup>	490 m
2,5 mm <sup>2</sup>	820 m

**BODY METAL SUPPLY LAR22 IS NOT WATERPROOF AND WILL NOT BE PLACE OUTSIDE THE PREMISES WITHOUT BEING PLACED IN TURN INSIDE A SEALED CONTAINER**





# TRASMITTER/RECEIVER

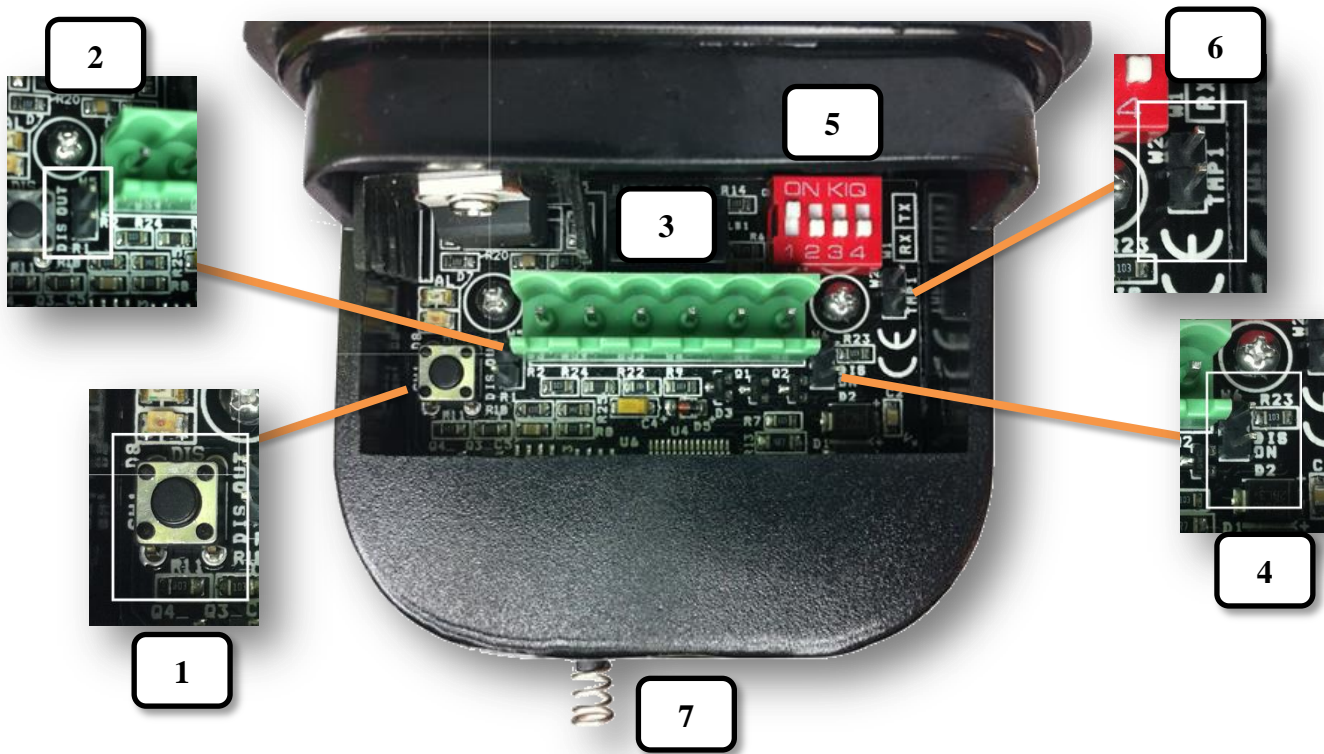

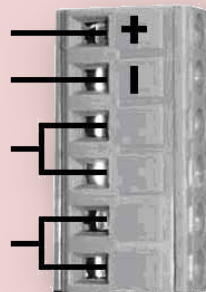
<b>1 Test button (only RX)</b>	when pressed allows you to access the functions of alignment
<b>2 DIS OUT (only RX)</b>	In case of disqualification activated gives output signal (NEGATIVE OPEN COLLECTOR)
<b>3 Terminals</b>	<div style="display: flex; align-items: center; justify-content: center;"> <div style="margin-right: 20px;">                     Power supply 10 – 30 VDC                       TAMPER contact                       Alarm contact N.C. (solo RX)                 </div>  </div>
<b>4 DIS ON (only RX)</b>	With inserted jumper enables the environmental disqualification and the monitoring output <b>Dis Out</b>
<b>5 Channel selector</b>	Moving the dip switch in ON (one at a time) enables a transmission channel, the same set to the TX must be corresponding to that of the RX
<b>6 Tmp 1</b>	Tamper input additional, in case of absence MUST remain closed by jumper
<b>7 Tmp</b>	Tamper anti cover removal



## 5. FREQUENCY SELECTION

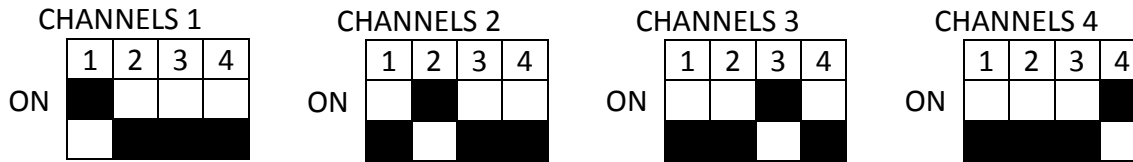

To compose barriers or dams with more than one pair of Ales, it is necessary to avoid interference assign a different channel to each of them. To do this you must turn ON dip switches on the desired channel on the mother board. The channel will be the same from both the transmitter from the receiver (ex. CHTX1 / CHRX1 - CHTX4 / CHRX4).

## 6. ALIGNMENT TEST

Press the TEST button on the RX mother board for 3 seconds until the buzzer will beep twice, accompanied by two blinking of LEDs, to begin calibration.

1. Press the TEST button on the RX Column

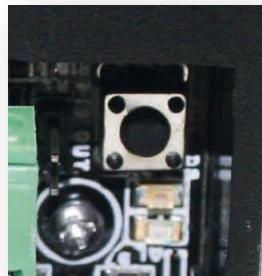

2. Power on of buzzer and LEDs on RX column



3. Align the optics placed in the column TX to RX, vertically and horizontally by turning the adjustment screws (horizontal and vertical) to find the maximum alignment. The condition of maximum alignment will be achieved when the LEDs are fixed and the buzzer will sound continuously. The condition of partial or total misalignment is indicated by flashing LEDs and low frequency whistle of buzzer.

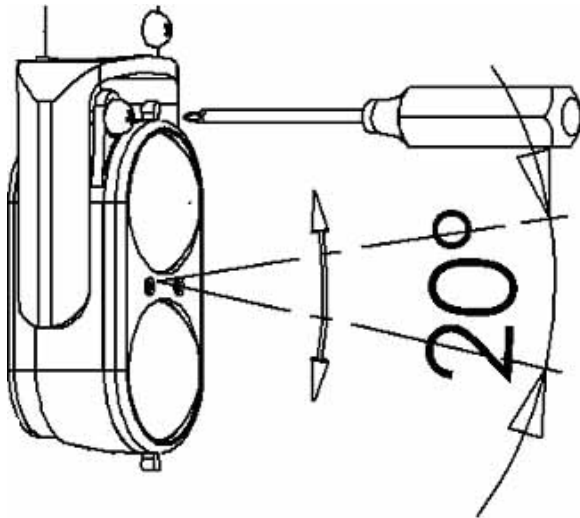

1. Vertical adjustment

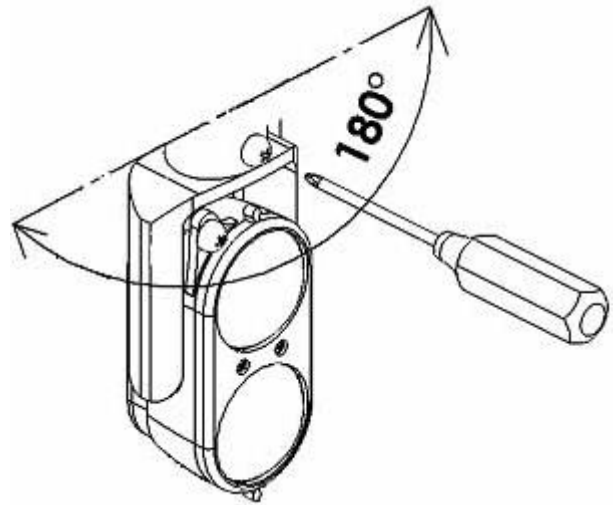

2. Horizontal adjustment

**To get a good alignment is necessary to make a complete rotation on the optics receiver horizontal axis, thus effecting the SCANNING of the optical signal.**

4. After obtained the calibration tighten the screw for horizontal adjustment, and exit from TEST mode by pressing the TEST button for 3 seconds on RX mother board. Two beeps of buzzer will indicate the end of the TEST function.

**NB: after adjusting for the next 3 minutes each alarm event will be highlighted by a beeper**

## 7. SETTING TIME

You can adjust the operating time of the optics such that the system goes into alarm, depending on usage and the location where it is installed in order to avoid false alarms.

CONFIGURATIONS:

Standard (t = 50 ms)	Intercept run
t = 250 ms	Pets disqualification
t = 500 ms	Wall application
t = 750 ms	Particular application

### TIME CHOICE

- Press the TEST button and perform the alignment.
- When alignment is performed, press the TEST button to exit the alignment mode and wait for the two consecutive beep of the buzzer.
- If you need the standard 50 ms delay time is not necessary to continue to the next step but wait for the confirmation BEEP at the end of the 5 seconds.
- Re-press the TEST button within 3 seconds at a time until you hear two consecutive BEEP to activate the mode of action 250 ms, continue to press the TEST button until you hear three consecutive BEEP and activates the mode of action 500 ms. And 'possible to obtain the means of intervention 750ms taking further down the TEST button until the fourth consecutive BEEP.
- To reset the time back to the first point of intervention.

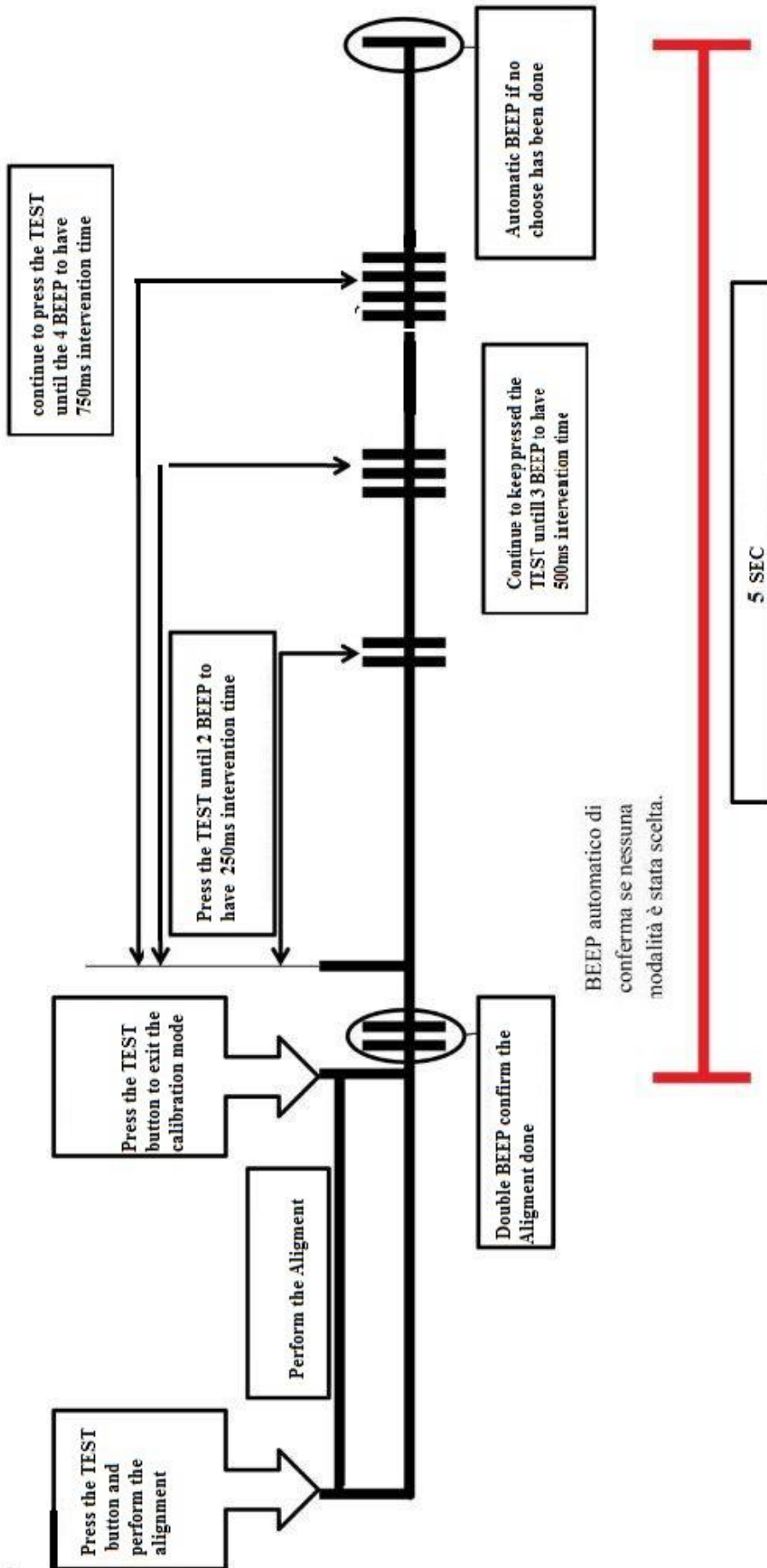

## 8. ENVIRONMENTAL DISQUALIFICATION

To obtain the message in the control panel of environmental disqualification, you must insert the jumper in DIS ON and connect a "OPEN COLLECTOR NEGATIVE" to the output DIS OUT. This feature allows output to the control panel of environmental disqualification, for which the barrier is in a standby state, this will avoid annoying false alarms caused by weather conditions.

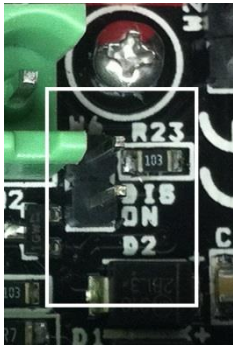

1. Insert jumper in DIS ON.

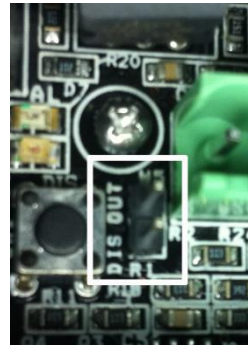

2. With the supplied cable connect the output OUT DIS (open collector negative) to bring the output in the control panel.

## 9. ADDITIONAL TAMPER

On mother boards TX and RX there is a supplementary Tamper input useful to add a wall tamper. In case of absence of additional Tamper, Check the closing of the contact by a jumper.

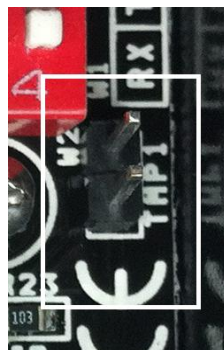

Tamper input additional, in case of absence  
MUST be closed by jumpers.

## 10. TECHNICAL FEATURES

<b>ALES 60/120</b>	
<b>Max range indoors</b>	250m / 480m
<b>Max range outdoors</b>	60m / 120m
<b>Synchronization</b>	4 optical channels
<b>Enviromental disqualification</b>	Yes with open collector output
<b>Setting intervention time</b>	4 setting
<b>Power supply</b>	10-30Vcc
<b>Heathers</b>	90mA
<b>Heathers comsumption (couple)</b>	Optional with termostat 10-30V: 10/15V = 6W, 0.4 A cad. 20/30V = 6W, 0.2 A cad.
<b>Tamper output</b>	contact NC
<b>Operating temperature</b>	-25° (with heater) +65°
<b>IP protection</b>	IP65
<b>Mounting brackets for wall/pole</b>	
<b>TOTAL WARRANTY 2 YEARS</b>	







**POLITEC s.r.l.**

Via Adda, 66/68 - 20882 Bellusco (MB) - Italy  
tel. +39 039 6883019 r.a. - fax +39 039 6200471  
[www.politecsrl.it](http://www.politecsrl.it)